

Constant Frequency Current Mode Step-Up DC/DC Controller in SOT-23

FEATURES

- High Efficiency: Over 90%
- High Output Currents Easily Achieved
- Wide V_{IN} Range: 2.5V to 9.8V
- V_{OUT} Limited Only by External Components
- Constant Frequency 550kHz Operation
- Burst Mode™ Operation at Light Load
- Current Mode Operation for Excellent Line and Load Transient Response
- Low Quiescent Current: 270 μ A
- Shutdown Mode Draws Only 8 μ A Supply Current
- $\pm 2.5\%$ Reference Accuracy
- Tiny 6-Lead SOT-23 Package

APPLICATIONS

- Lithium-Ion-Powered Applications
- Cellular Telephones
- Wireless Modems
- Portable Computers
- Scanners

DESCRIPTION

The LTC[®]1872 is a constant frequency current mode step-up DC/DC controller providing excellent AC and DC load and line regulation. The device incorporates an accurate undervoltage lockout feature that shuts down the LTC1872 when the input voltage falls below 2.0V.

The LTC1872 boasts a $\pm 2.5\%$ output voltage accuracy and consumes only 270 μ A of quiescent current. For applications where efficiency is a prime consideration, the LTC1872 is configured for Burst Mode operation, which enhances efficiency at low output current.

In shutdown, the device draws a mere 8 μ A. The high 550kHz constant operating frequency allows the use of a small external inductor.

The LTC1872 is available in a small footprint 6-lead SOT-23.

LT, LTC and LT are registered trademarks of Linear Technology Corporation. Burst Mode is a trademark of Linear Technology Corporation.

TYPICAL APPLICATION

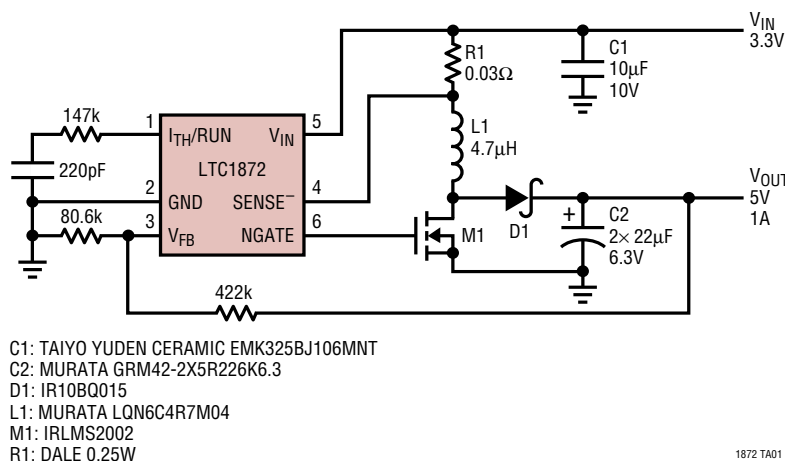
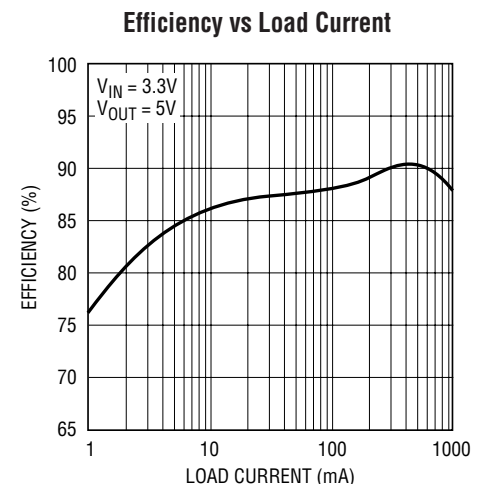

Figure 1. LTC1872 High Output Current 3.3V to 5V Boost Converter



1872 TAO1b

ABSOLUTE MAXIMUM RATINGS

(Note 1)

Input Supply Voltage (V_{IN})	-0.3V to 10V
SENSE ⁻ , NGATE Voltages	-0.3V to ($V_{IN} + 0.3V$)
V_{FB} , I_{TH}/RUN Voltages	-0.3V to 2.4V
NGATE Peak Output Current (<10 μ s)	1A
Storage Ambient Temperature Range	-65°C to 150°C
Operating Temperature Range (Note 2)	-40°C to 85°C
Junction Temperature (Note 3)	150°C
Lead Temperature (Soldering, 10 sec)	300°C

PACKAGE/ORDER INFORMATION

	ORDER PART NUMBER
	LTC1872ES6
	S6 PART MARKING
	LTMK

Consult factory for parts specified with wider operating temperature ranges.

ELECTRICAL CHARACTERISTICS

The ● denotes specifications that apply over the full operating temperature range, otherwise specifications are at $T_A = 25^\circ\text{C}$. $V_{IN} = 4.2\text{V}$ unless otherwise specified. (Note 2)

PARAMETER	CONDITIONS	MIN	TYP	MAX	UNITS	
Input DC Supply Current	Typicals at $V_{IN} = 4.2\text{V}$ (Note 4)					
	Normal Operation		270	420	μA	
	Sleep Mode		230	370	μA	
	Shutdown		8	22	μA	
UVLO	$V_{IN} < \text{UVLO Threshold}$		6	10	μA	
Undervoltage Lockout Threshold	V_{IN} Falling	● 1.55	2.00	2.35	V	
	V_{IN} Rising	● 1.85	2.10	2.40	V	
Shutdown Threshold (at I_{TH}/RUN)		● 0.15	0.35	0.55	V	
Start-Up Current Source	$V_{ITH}/RUN = 0\text{V}$		0.25	0.5	0.85	μA
Regulated Feedback Voltage	0°C to 70°C (Note 5)	● 0.780	0.800	0.820	V	
	-40°C to 85°C (Note 5)	● 0.770	0.800	0.830	V	
V_{FB} Input Current	(Note 5)		10	50	nA	
Oscillator Frequency	$V_{FB} = 0.8\text{V}$		500	550	650	kHz
Gate Drive Rise Time	$C_{LOAD} = 3000\text{pF}$			40	ns	
Gate Drive Fall Time	$C_{LOAD} = 3000\text{pF}$			40	ns	
Peak Current Sense Voltage	(Note 6)		114	120	mV	

Note 1: Absolute Maximum Ratings are those values beyond which the life of a device may be impaired.

Note 2: The LTC1872E is guaranteed to meet performance specifications from 0°C to 70°C. Specifications over the -40°C to 85°C operating temperature range are assured by design, characterization and correlation with statistical process controls.

Note 3: T_J is calculated from the ambient temperature T_A and power dissipation P_D according to the following formula:

$$T_J = T_A + (P_D \cdot \theta_{JA})^\circ\text{C/W}$$

Note 4: Dynamic supply current is higher due to the gate charge being delivered at the switching frequency.

Note 5: The LTC1872 is tested in a feedback loop that serves V_{FB} to the output of the error amplifier.

Note 6: Guaranteed by design at duty cycle = 30%. Peak current sense voltage is $V_{REF}/6.67$ at duty cycle <40%, and decreases as duty cycle increases due to slope compensation as shown in Figure 2.

TYPICAL PERFORMANCE CHARACTERISTICS

Reference Voltage vs Temperature

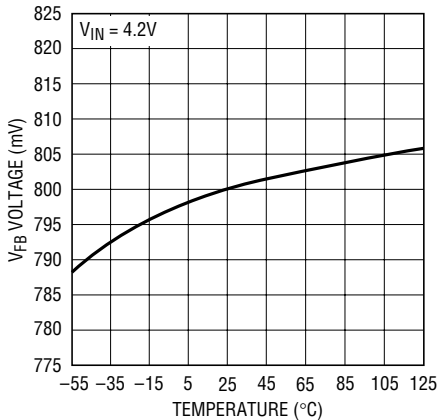

1872 G01

Normalized Oscillator Frequency vs Temperature

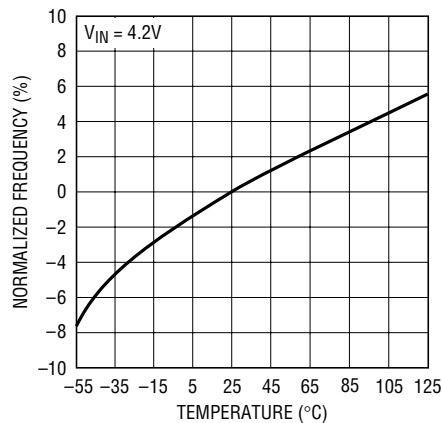

1872 G02

Undervoltage Lockout Trip Voltage vs Temperature

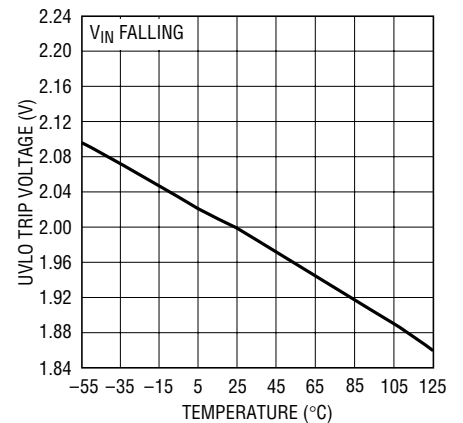

1872 G03

Maximum Current Sense Trip Voltage vs Duty Cycle

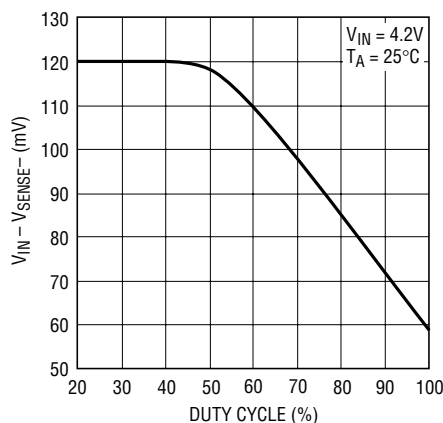

1872 G04

Shutdown Threshold vs Temperature

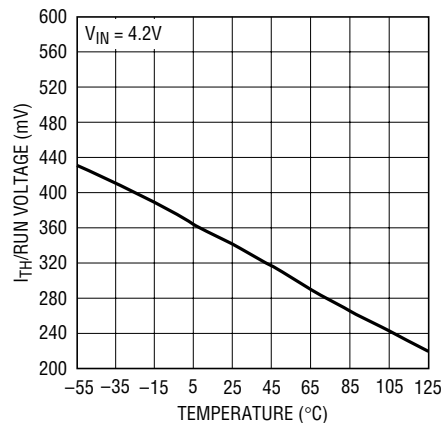

1872 G05

PIN FUNCTIONS

I_{TH}/RUN (Pin 1): This pin performs two functions. It serves as the error amplifier compensation point as well as the run control input. Nominal voltage range for this pin is 0.7V to 1.9V. Forcing this pin below 0.35V causes the device to be shut down. In shutdown all functions are disabled and the NGATE pin is held low.

GND (Pin 2): Ground Pin.

V_{FB} (Pin 3): Receives the feedback voltage from an external resistive divider across the output.

SENSE⁻ (Pin 4): The Negative Input to the Current Comparator.

V_{IN} (Pin 5): Supply Pin. Must be closely decoupled to GND Pin 2.

NGATE (Pin 6): Gate Drive for the External N-Channel MOSFET. This pin swings from 0V to V_{IN}.

FUNCTIONAL DIAGRAM

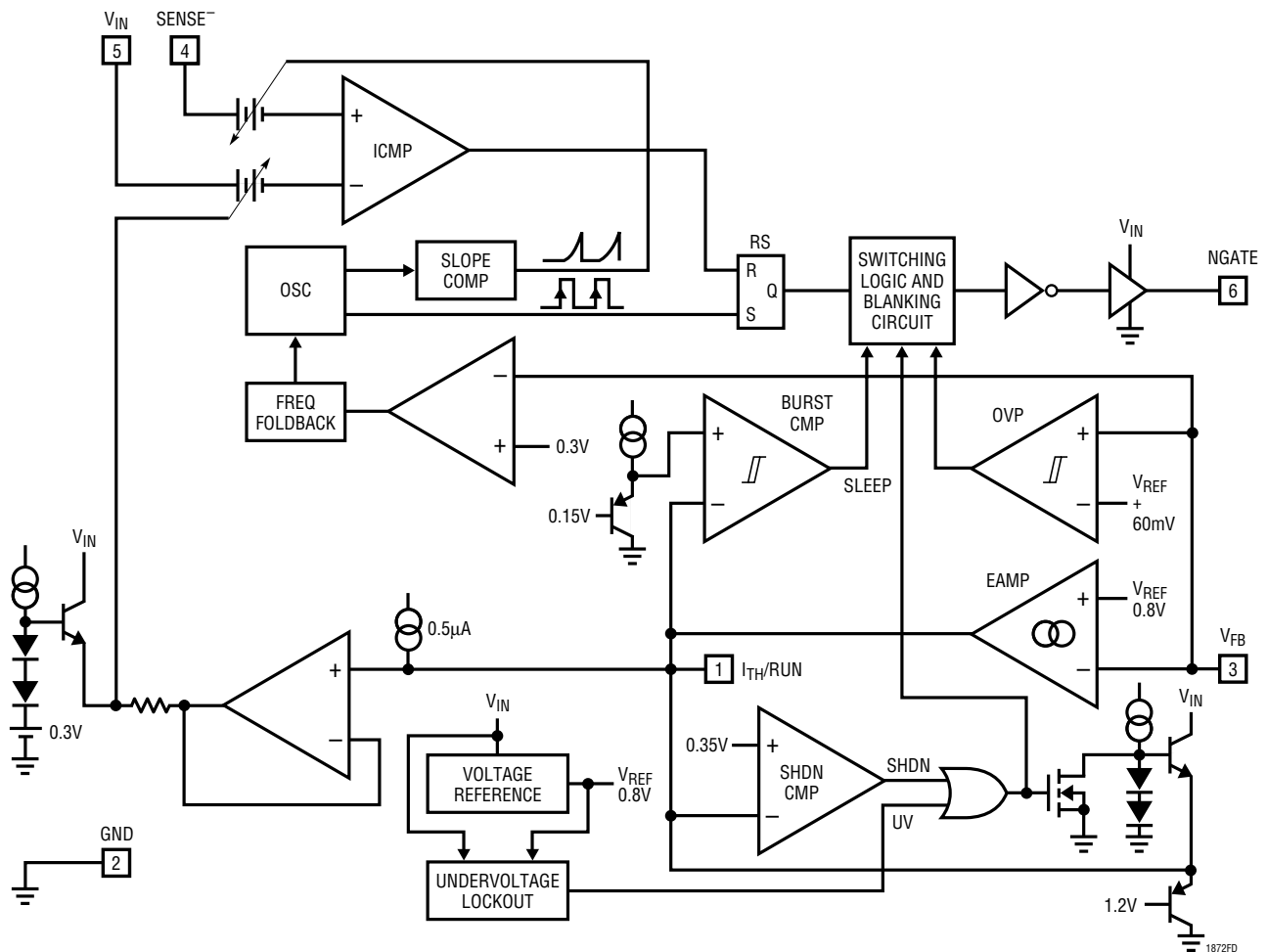

OPERATION (Refer to Functional Diagram)

Main Control Loop

The LTC1872 is a constant frequency current mode switching regulator. During normal operation, the external N-channel power MOSFET is turned on each cycle by the oscillator and turned off when the current comparator (ICMP) resets the RS latch. The peak inductor current at which ICMP resets the RS latch is controlled by the voltage on the I_{TH}/RUN pin, which is the output of the error amplifier EAMP. An external resistive divider connected between V_{OUT} and ground allows the EAMP to receive an output feedback voltage V_{FB} . When the load current increases, it causes a slight decrease in V_{FB} relative to the

0.8V reference, which in turn causes the I_{TH}/RUN voltage to increase until the average inductor current matches the new load current.

The main control loop is shut down by pulling the I_{TH}/RUN pin low. Releasing I_{TH}/RUN allows an internal $0.5\mu A$ current source to charge up the external compensation network. When the I_{TH}/RUN pin reaches 0.35V, the main control loop is enabled with the I_{TH}/RUN voltage then pulled up to its zero current level of approximately 0.7V. As the external compensation network continues to charge up, the corresponding output current trip level follows, allowing normal operation.

OPERATION (Refer to Functional Diagram)

Comparator OVP guards against transient overshoots >7.5% by turning off the external N-channel power MOSFET and keeping it off until the fault is removed.

Burst Mode Operation

The LTC1872 enters Burst Mode operation at low load currents. In this mode, the peak current of the inductor is set as if $V_{I_{TH}/RUN} = 1V$ (at low duty cycles) even though the voltage at the I_{TH}/RUN pin is at a lower value. If the inductor's average current is greater than the load requirement, the voltage at the I_{TH}/RUN pin will drop. When the I_{TH}/RUN voltage goes below 0.85V, the sleep signal goes high, turning off the external MOSFET. The sleep signal goes low when the I_{TH}/RUN voltage goes above 0.925V and the LTC1872 resumes normal operation. The next oscillator cycle will turn the external MOSFET on and the switching cycle repeats.

Undervoltage Lockout

To prevent operation of the N-channel MOSFET below safe input voltage levels, an undervoltage lockout is incorporated into the LTC1872. When the input supply voltage drops below approximately 2.0V, the N-channel MOSFET and all circuitry is turned off except the undervoltage block, which draws only several microamperes.

Overvoltage Protection

The overvoltage comparator in the LTC1872 will turn the external MOSFET off when the feedback voltage has risen 7.5% above the reference voltage of 0.8V. This comparator has a typical hysteresis of 20mV.

Slope Compensation and Inductor's Peak Current

The inductor's peak current is determined by:

$$I_{PK} = \frac{V_{I_{TH}} - 0.7}{10(R_{SENSE})}$$

when the LTC1872 is operating below 40% duty cycle. However, once the duty cycle exceeds 40%, slope compensation begins and effectively reduces the peak inductor current. The amount of reduction is given by the curves in Figure 2.

Short-Circuit Protection

Since the power switch in a boost converter is not in series with the power path from input to load, turning off the switch provides no protection from a short-circuit at the output. External means such as a fuse in series with the boost inductor must be employed to handle this fault condition.

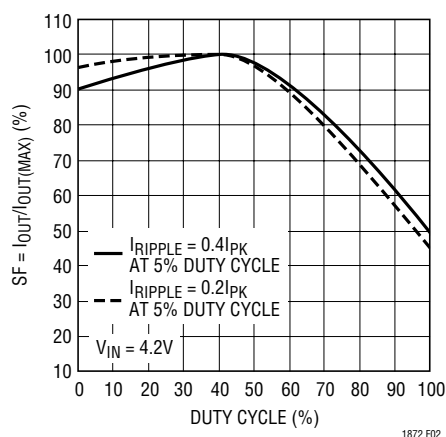

Figure 2. Maximum Output Current vs Duty Cycle

APPLICATIONS INFORMATION

The basic LTC1872 application circuit is shown in Figure 1. External component selection is driven by the load requirement and begins with the selection of L1 and R_{SENSE} (= R1). Next, the power MOSFET and the output diode D1 is selected followed by C_{IN}(= C1) and C_{OUT}(= C2).

R_{SENSE} Selection for Output Current

R_{SENSE} is chosen based on the required output current. With the current comparator monitoring the voltage developed across R_{SENSE}, the threshold of the comparator determines the inductor's peak current. The output current the LTC1872 can provide is given by:

$$I_{OUT} = \left(\frac{0.12}{R_{SENSE}} - \frac{I_{RIPPLE}}{2} \right) \frac{V_{IN}}{V_{OUT} + V_D}$$

where I_{RIPPLE} is the inductor peak-to-peak ripple current (see Inductor Value Calculation section) and V_D is the forward drop of the output diode at the full rated output current.

A reasonable starting point for setting ripple current is:

$$I_{RIPPLE} = (0.4)(I_{OUT}) \frac{V_{OUT} + V_D}{V_{IN}}$$

Rearranging the above equation, it becomes:

$$R_{SENSE} = \frac{1}{(10)(I_{OUT})} \left(\frac{V_{IN}}{V_{OUT} + V_D} \right)$$

for Duty Cycle < 40%

However, for operation that is above 40% duty cycle, slope compensation's effect has to be taken into consideration to select the appropriate value to provide the required amount of current. Using the scaling factor (SF, in %) in Figure 2, the value of R_{SENSE} is:

$$R_{SENSE} = \frac{SF}{(10)(I_{OUT})(100)} \left(\frac{V_{IN}}{V_{OUT} + V_D} \right)$$

Inductor Value Calculation

The operating frequency and inductor selection are inter-related in that higher operating frequencies permit the use of a smaller inductor for the same amount of inductor ripple current. However, this is at the expense of efficiency due to an increase in MOSFET gate charge losses.

The inductance value also has a direct effect on ripple current. The ripple current, I_{RIPPLE}, decreases with higher inductance or frequency and increases with higher V_{OUT}. The inductor's peak-to-peak ripple current is given by:

$$I_{RIPPLE} = \frac{V_{IN}}{f(L)} \left(\frac{V_{OUT} + V_D - V_{IN}}{V_{OUT} + V_D} \right)$$

where f is the operating frequency. Accepting larger values of I_{RIPPLE} allows the use of low inductances, but results in higher output voltage ripple and greater core losses. A reasonable starting point for setting ripple current is:

$$I_{RIPPLE} = 0.4 \left(I_{OUT(MAX)} \right) \left(\frac{V_{OUT} + V_D}{V_{IN}} \right)$$

In Burst Mode operation, the ripple current is normally set such that the inductor current is continuous during the burst periods. Therefore, the peak-to-peak ripple current must not exceed:

$$I_{RIPPLE} \leq \frac{0.03}{R_{SENSE}}$$

This implies a minimum inductance of:

$$L_{MIN} = \frac{V_{IN}}{f \left(\frac{0.03}{R_{SENSE}} \right)} \left(\frac{V_{OUT} + V_D - V_{IN}}{V_{OUT} + V_D} \right)$$

A smaller value than L_{MIN} could be used in the circuit; however, the inductor current will not be continuous during burst periods.

APPLICATIONS INFORMATION

Inductor Selection

When selecting the inductor, keep in mind that inductor saturation current has to be greater than the current limit set by the current sense resistor. Also, keep in mind that the DC resistance of the inductor will affect the efficiency. Off the shelf inductors are available from Murata, Coilcraft, Toko, Panasonic, Coiltronics and many other suppliers.

Power MOSFET Selection

The main selection criteria for the power MOSFET are the threshold voltage $V_{GS(TH)}$, the “on” resistance $R_{DS(ON)}$, reverse transfer capacitance C_{RSS} and total gate charge.

Since the LTC1872 is designed for operation down to low input voltages, a logic level threshold MOSFET ($R_{DS(ON)}$ guaranteed at $V_{GS} = 2.5V$) is required for applications that work close to this voltage. When these MOSFETs are used, make sure that the input supply to the LTC1872 is less than the absolute maximum V_{GS} rating, typically 8V.

The required minimum $R_{DS(ON)}$ of the MOSFET is governed by its allowable power dissipation given by:

$$R_{DS(ON)} \cong \frac{P_P}{(DC)I_{IN}^2(1 + \delta p)}$$

where P_P is the allowable power dissipation and δp is the temperature dependency of $R_{DS(ON)}$. $(1 + \delta p)$ is generally given for a MOSFET in the form of a normalized $R_{DS(ON)}$ vs temperature curve, but $\delta p = 0.005/^\circ C$ can be used as an approximation for low voltage MOSFETs. DC is the maximum operating duty cycle of the LTC1872.

Output Diode Selection

Under normal load conditions, the average current conducted by the diode in a boost converter is equal to the output load current:

$$I_{D(avg)} = I_{OUT}$$

It is important to adequately specify the diode peak current and average power dissipation so as not to exceed the diode ratings.

Schottky diodes are recommended for low forward drop and fast switching times. Remember to keep lead length short and observe proper grounding (see Board Layout Checklist) to avoid ringing and increased dissipation.

C_{IN} and C_{OUT} Selection

To prevent large input voltage ripple, a low ESR input capacitor sized for the maximum RMS current must be used. The maximum RMS capacitor current for a boost converter is approximately equal to:

$$C_{IN} \text{ Required } I_{RMS} \approx (0.3)I_{RIPPLE}$$

where I_{RIPPLE} is as defined in the Inductor Value Calculation section.

Note that capacitor manufacturer’s ripple current ratings are often based on 2000 hours of life. This makes it advisable to further derate the capacitor, or to choose a capacitor rated at a higher temperature than required. Several capacitors may be paralleled to meet the size or height requirements in the design. Due to the high operating frequency of the LTC1872, ceramic capacitors can also be used for C_{IN} . Always consult the manufacturer if there is any question.

The selection of C_{OUT} is driven by the required effective series resistance (ESR). Typically, once the ESR requirement is satisfied, the capacitance is adequate for filtering. The output ripple (ΔV_{OUT}) is approximated by:

$$\Delta V_{OUT} \approx \left(I_O \cdot \frac{V_{OUT} + V_D}{V_{IN}} + \frac{I_{RIPPLE}}{2} \right) \cdot \left[ESR^2 + \left(\frac{1}{2\pi f C_{OUT}} \right)^2 \right]^{\frac{1}{2}}$$

APPLICATIONS INFORMATION

where f is the operating frequency, C_{OUT} is the output capacitance and I_{RIPPLE} is the ripple current in the inductor.

Manufacturers such as Nichicon, United Chemicon and Sanyo should be considered for high performance through-hole capacitors. The OS-CON semiconductor dielectric capacitor available from Sanyo has the lowest ESR (size) product of any aluminum electrolytic at a somewhat higher price. The output capacitor RMS current is approximately equal to:

$$I_{PK} \cdot \sqrt{DC - DC^2}$$

where I_{PK} is the peak inductor current and DC is the switch duty cycle.

When using electrolytic output capacitors, if the ripple and ESR requirements are met, there is likely to be far more capacitance than required.

In surface mount applications, multiple capacitors may have to be paralleled to meet the ESR or RMS current handling requirements of the application. Aluminum electrolytic and dry tantalum capacitors are both available in surface mount configurations. An excellent choice of tantalum capacitors is the AVX TPS and KEMET T510 series of surface mount tantalum capacitors. Also, ceramic capacitors in X5R or X7R dielectrics offer excellent performance.

Low Supply Operation

Although the LTC1872 can function down to approximately 2.0V, the maximum allowable output current is reduced when V_{IN} decreases below 3V. Figure 3 shows the amount of change as the supply is reduced down to 2V. Also shown in Figure 3 is the effect of V_{IN} on V_{REF} as V_{IN} goes below 2.3V.

Setting Output Voltage

The LTC1872 develops a 0.8V reference voltage between the feedback (Pin 3) terminal and ground (see Figure 4). By selecting resistor $R1$, a constant current is caused to flow through $R1$ and $R2$ to set the overall output voltage. The regulated output voltage is determined by:

$$V_{OUT} = 0.8V \left(1 + \frac{R2}{R1} \right)$$

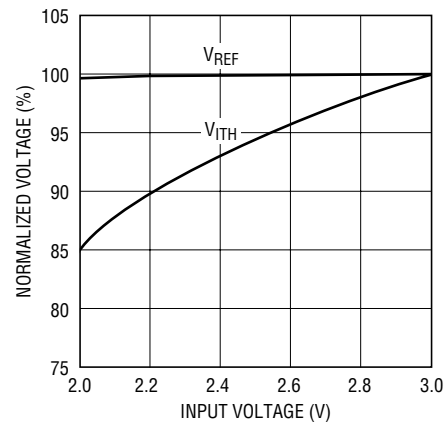

1872 F03

Figure 3. Line Regulation of V_{REF} and V_{ITH}

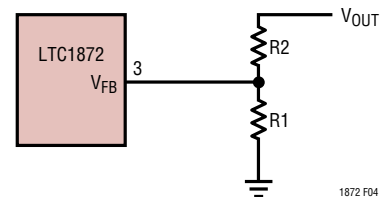

1872 F04

Figure 4. Setting Output Voltage

APPLICATIONS INFORMATION

For most applications, an 80k resistor is suggested for R1. To prevent stray pickup, locate resistors R1 and R2 close to LTC1872.

Efficiency Considerations

The efficiency of a switching regulator is equal to the output power divided by the input power times 100%. It is often useful to analyze individual losses to determine what is limiting the efficiency and which change would produce the most improvement. Efficiency can be expressed as:

$$\text{Efficiency} = 100\% - (\eta_1 + \eta_2 + \eta_3 + \dots)$$

where η_1 , η_2 , etc. are the individual losses as a percentage of input power.

Although all dissipative elements in the circuit produce losses, four main sources usually account for most of the losses in LTC1872 circuits: 1) LTC1872 DC bias current, 2) MOSFET gate charge current, 3) I^2R losses and 4) voltage drop of the output diode.

1. The V_{IN} current is the DC supply current, given in the electrical characteristics, that excludes MOSFET driver and control currents. V_{IN} current results in a small loss which increases with V_{IN} .

2. MOSFET gate charge current results from switching the gate capacitance of the power MOSFET. Each time a MOSFET gate is switched from low to high to low again, a packet of charge, dQ , moves from V_{IN} to ground. The resulting dQ/dt is a current out of V_{IN} which is typically much larger than the controller's DC supply current. In continuous mode, $I_{GATECHG} = f(Q_p)$.
3. I^2R losses are predicted from the DC resistances of the MOSFET, inductor and current sense resistor. The MOSFET $R_{DS(ON)}$ multiplied by duty cycle times the average output current squared can be summed with I^2R losses in the inductor ESR in series with the current sense resistor.
4. The output diode is a major source of power loss at high currents. The diode loss is calculated by multiplying the forward voltage by the load current.
5. Transition losses apply to the external MOSFET and increase at higher operating frequencies and input voltages. Transition losses can be estimated from:

$$\text{Transition Loss} = 2(V_{IN})^2 I_{IN(MAX)} C_{RSS}(f)$$

Other losses, including C_{IN} and C_{OUT} ESR dissipative losses, and inductor core losses, generally account for less than 2% total additional loss.

APPLICATIONS INFORMATION

PC Board Layout Checklist

When laying out the printed circuit board, the following checklist should be used to ensure proper operation of the LTC1872. These items are illustrated graphically in the layout diagram in Figure 5. Check the following in your layout:

1. The Schottky diode should be closely connected between the output capacitor and the drain of the external MOSFET.
2. The (+) plate of C_{IN} should connect to the sense resistor as closely as possible. This capacitor provides AC current to the inductor.
3. The input decoupling capacitor ($0.1\mu\text{F}$) should be connected closely between V_{IN} (Pin 5) and ground (Pin 2).
4. Connect the end of R_{SENSE} as close to V_{IN} (Pin 5) as possible. The V_{IN} pin is the SENSE^+ of the current comparator.
5. The trace from SENSE^- (Pin 4) to the Sense resistor should be kept short. The trace should connect close to R_{SENSE} .
6. Keep the switching node NGATE away from sensitive small signal nodes.
7. The V_{FB} pin should connect directly to the feedback resistors. The resistive divider $R1$ and $R2$ must be connected between the (+) plate of C_{OUT} and signal ground.

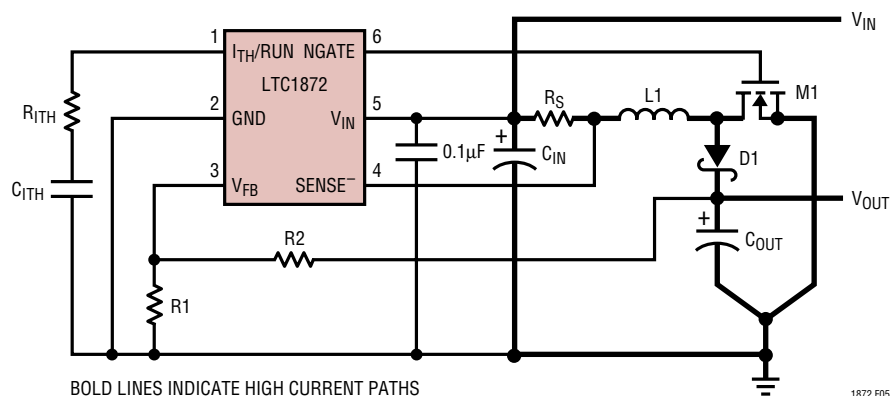
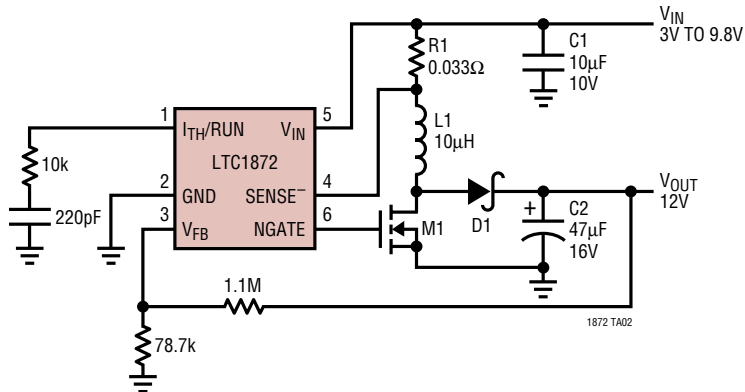

Figure 5. LTC1872 Layout Diagram (See PC Board Layout Checklist)

TYPICAL APPLICATION

LTC1872 12V/500mA Boost Converter



- | | |
|--|--------------------------|
| C1: TAIYO YUDEN CERAMIC EMK325BJ106MNT | L1: COILTRONICS UP2B-100 |
| C2: AVX TPSE476M016R0150 | M1: Si9804DV |
| D1: IR10BQ015 | R1: DALE 0.25W |

LTC1872 Three-Cell White LED Driver

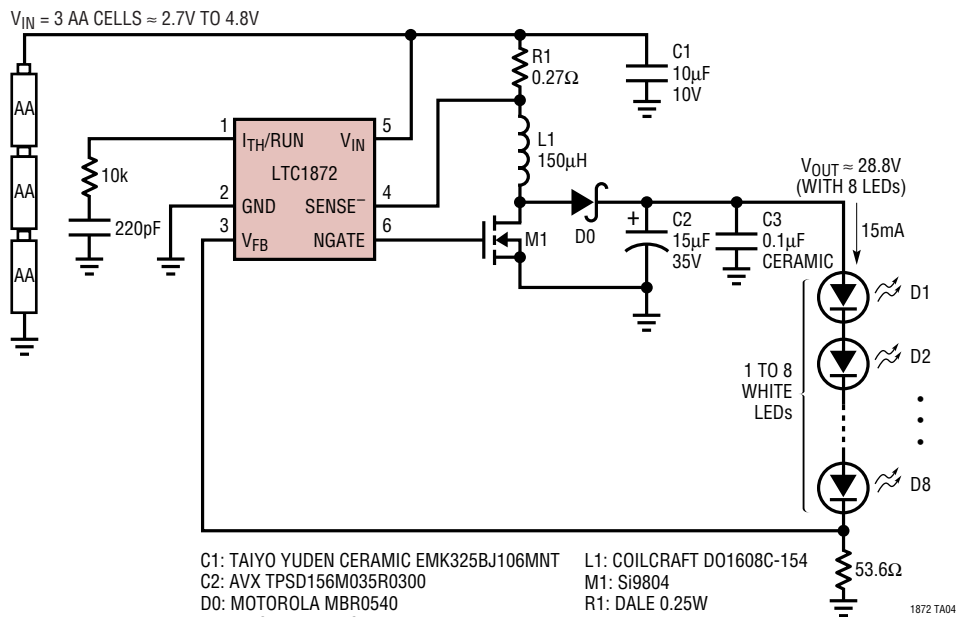

- | | |
|--|---------------------------|
| C1: TAIYO YUDEN CERAMIC EMK325BJ106MNT | L1: COILCRAFT DO1608C-154 |
| C2: AVX TPSD156M035R0300 | M1: Si9804 |
| D0: MOTOROLA MBR0540 | R1: DALE 0.25W |
| D1-D7: CMD333UWC | |

TYPICAL APPLICATION

LTC1872 –2.5V to 3.3V/0.5A Boost Converter

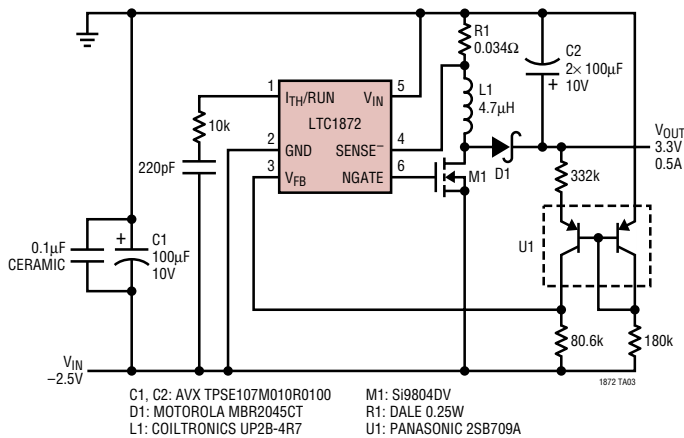

LTC1872 2.7V to 9.8V Input to 3.3V/1.2A Output SEPIC Converter

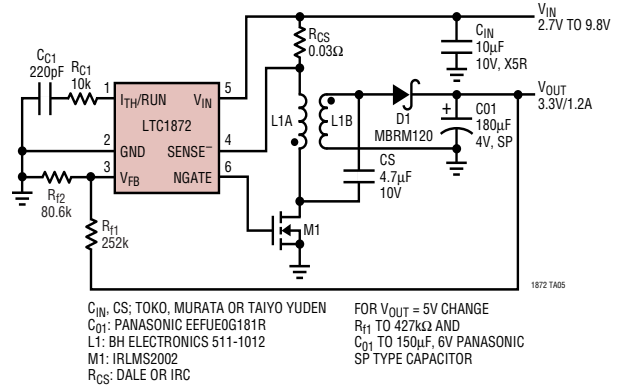

PACKAGE DESCRIPTION

Dimensions in inches (millimeters) unless otherwise noted.

S6 Package
 6-Lead Plastic SOT-23
 (LTC DWG # 05-08-1634)

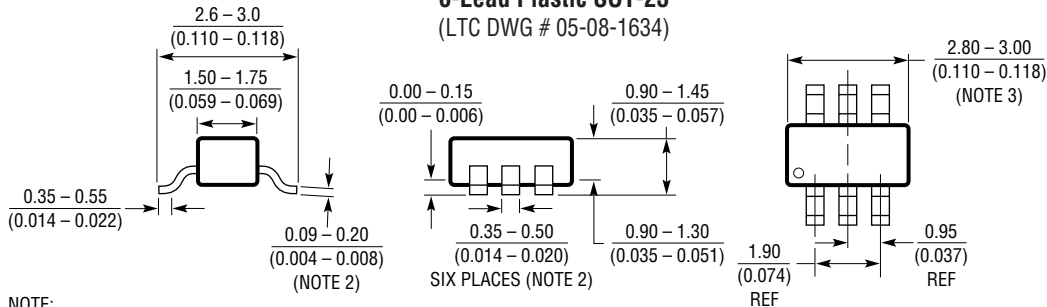

- NOTE:
- DIMENSIONS ARE IN MILLIMETERS
 - DIMENSIONS ARE INCLUSIVE OF PLATING
 - DIMENSIONS ARE EXCLUSIVE OF MOLD FLASH AND METAL BURR
 - MOLD FLASH SHALL NOT EXCEED 0.254mm
 - PACKAGE EIAJ REFERENCE IS SC-74A (EIAJ)

S6 SOT-23 0898

RELATED PARTS

PART NUMBER	DESCRIPTION	COMMENTS
LT1304	Micropower DC/DC Converter with Low-Battery Detector	120µA Quiescent Current, 1.5V ≤ V _{IN} ≤ 8V
LT1610	1.7MHz, Single Cell Micropower DC/DC Converter	30µA Quiescent Current, V _{IN} Down to 1V
LT1613	1.4MHz, Single Cell DC/DC Converter in 5-Lead SOT-23	Internally Compensated, V _{IN} Down to 1V
LT1619	Low Voltage Current Mode PWM Controller	8-Lead MSOP Package, 1.9V ≤ V _{IN} ≤ 18V
LT1680	High Power DC/DC Step-Up Controller	Operation Up to 60V, Fixed Frequency Current Mode
LTC1624	High Efficiency SO-8 N-Channel Switching Regulator Controller	8-Pin N-Channel Drive, 3.5V ≤ V _{IN} ≤ 36V
LT1615	Micropower Step-Up DC/DC Converter in SOT-23	20µA Quiescent Current, V _{IN} Down to 1V
LTC1700	No R _{SENSE} Synchronous Current Mode DC/DC Step-Up Controller	95% Efficient, 0.9V ≤ V _{IN} ≤ 5V, 550kHz Operation
LTC1772	Constant Frequency Current Mode Step-Down DC/DC Controller	V _{IN} 2.5V to 9.8V, I _{OUT} up to 4A, SOT-23 Package
LTC3401/LTC3402	1A/2A, 3MHz Micropower Synchronous Boost Converter	10-Lead MSOP Package, 0.5V ≤ V _{IN} ≤ 5V