

## Standalone Linear Lithium Battery Charger

### Description

The TQ7051 device is highly advanced linear charge management controllers for use in space-limited, cost-sensitive applications. The TQ7051 is available in a 5-Lead, SOT23 package. Along with their small physical size, the low number of external components required make the TQ7051 ideally suited for portable applications.

No external sense resistor is needed, and no blocking diode is required due to the internal MOSFET architecture. Thermal feedback regulates the charge current to limit the die temperature during high power operation or high ambient temperature. The charge voltage is fixed at 4.2V, and the charge current can be programmed externally with a single resistor. The TQ7051 automatically terminates the charge cycle when the charge current drops to 1/10th the programmed value after the final float voltage is reached. When the input supply is removed, the TQ7051 automatically enters a low current stage, dropping the battery drain current to less than 2µA. The TQ7051 can be put into shutdown mode, reducing the supply current to 25µA.

Other features include charge current monitor, undervoltage lockout, automatic recharge and a status pin to indicate charge termination and the presence of an input voltage.

### Features

- + Programmable Charge Current Up to 800mA.
- + No MOSFET, Sense Resistor or Blocking Diode Required.
- + Constant-Current/Constant-Voltage Operation with Thermal Protection to Maximize ChargeRate without Risk of Overheating.
- + Charges Single Cell Li-Ion Batteries Directly from USB Port.
- + Preset 4.2V Charge Voltage with  $\pm 1\%$  Accuracy.
- + 25µA Supply Current in Shutdown.
- + 2.9V Trickle Charge Threshold
- + Available Without Trickle Charge.
- + Soft-Start Limits Inrush Current.
- + Available in 5-Lead SOT-23 Package.

### Application

- + Cellular Telephones, PDA's, MP3 Players.
- + Charging Docks and Cradles
- + Bluetooth Applications

### Pin Configuration

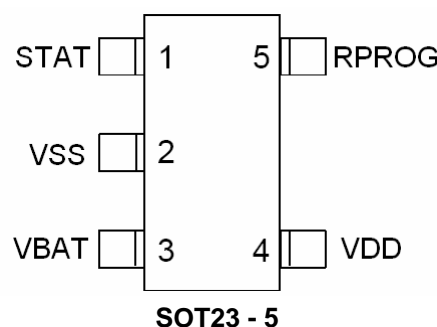

**Pin Function**

Pin No.	Pin Name	Function Description
1	$\overline{\text{CHRG}}$	Open-Drain Charge Status Output.
2	GND	Ground
3	BAT	Charge Current Output. Provides charge current to the battery and regulates the final float voltage o 4.2V.
4	Vcc	Positive Input Supply Voltage. Provides power to the charger. VCC can range from 4.3V to 6.5V and should be bypassed with at least a 1 $\mu$ F capacitor.
5	PROG	Charge Current Program, Charge Current monitor and Shutdown Pin. The charge current is programmed by connecting a 1% resistor RPROG to ground.

**Typical Application Diagram**

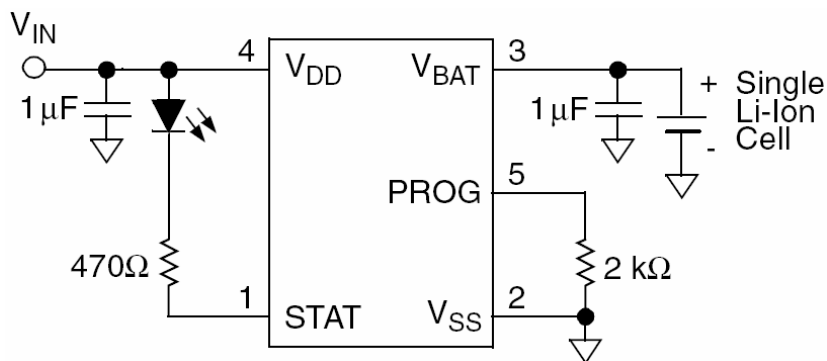

**500mA Single Cell Li-Ion Charger**

**Absolute Maximum Ratings†**

Vcc(Input Supply Voltage) .....	10V
All Inputs and Outputs w.r.t. VSS .....	-0.3 to (VDD+0.3)V
BAT Voltage .....	7 V
BAT Pin Current .....	800mA
Storage temperature .....	-65°C to +125°C

† **Notice:** Stresses above those listed under “Maximum Ratings” may cause permanent damage to the device. This is a stress rating only and functional operation of the device at those or any other conditions above those indicated in the operational listings of this specification is not implied. Exposure to maximum rating conditions for extended periods may affect device reliability.

## Electrical Characteristics

$V_{IN} = 5V$ ;  $T_J = 25^{\circ}C$ ; unless otherwise specified.

Symbol	Parameter	Conditions	Min	Typ	Max	Unit
$V_{CC}$	Input Supply Voltage		4.25		6	V
$I_{CC}$	Input Supply Current	Charge Mode <sup>(3)</sup> , $R_{PROG} = 10k$		190		$\mu A$
		Standby Mode (Charge Terminated)		85		$\mu A$
		Shutdown Mode ( $R_{PROG}$ Not Connected, $V_{CC} < V_{BAT}$ , or $V_{CC} < V_{UV}$ )		12		$\mu A$
$V_{FLOAT}$	Regulated Output (Float) Voltage	$0^{\circ}C \leq T_J \leq 85^{\circ}C$ , $I_{BAT} = 40mA$		4.2		V
$I_{BAT}$	BAT Pin Current	$R_{PROG} = 10k$ , Current Mode		110		mA
		$R_{PROG} = 2k$ , Current Mode		500		mA
		Standby Mode, $V_{BAT} = 4.2V$		4		$\mu A$
		Shutdown Mode ( $R_{PROG}$ Not Connected)		$\pm 1$		$\mu A$
		Sleep Mode, $V_{CC} = 0V$		$\pm 1$		$\mu A$
$I_{TRIKL}$	Trickle Charge Current	$V_{BAT} < V_{TRIKL}$ , $R_{PROG} = 10k$		12		mA
$V_{TRIKL}$	Trickle Charge Threshold Voltage	$R_{PROG} = 10k$ , $V_{BAT}$ Rising		2.9		V
$V_{UV}$	$V_{CC}$ Undervoltage Lockout Threshold	From $V_{CC}$ Low to High		3.4		V
$V_{UVHYS}$	$V_{CC}$ Undervoltage Lockout Hysteresis			170		mV
$V_{MSD}$	Manual Shutdown Threshold Voltage	PROG Pin Rising		1.25		V
		PROG Pin Falling		1.2		V
$V_{ASD}$	$V_{CC} - V_{BAT}$ Lockout Threshold Voltage	$V_{CC}$ from Low to High		100		mV
		$V_{CC}$ from High to Low		30		mV
$I_{TERM}$	C/10 Termination Current Threshold	$R_{PROG} = 10k^{(4)}$		0.1		mA/mA
		$R_{PROG} = 2k$		0.1		mA/mA
$V_{PROG}$	PROG Pin Voltage	$R_{PROG} = 10k$ , Current Mode		1.03		V
$I_{CHRG}$	CHRG Pin Weak Pull-Down Current	$V_{CHRG} = 5V$		20		$\mu A$
$V_{CHRG}$	CHRG Pin Output Low Voltage	$I_{CHRG} = 5mA$		0.35		V
$\Delta V_{RECHRG}$	Recharge Battery Threshold Voltage	$V_{FLOAT} - V_{RECHRG}$		100		mV
$T_{LIM}$	Thermal Protection Temperature			120		$^{\circ}C$
$t_{SS}$	Soft-Start Time	$I_{BAT} = 0$ to $1000V/R_{PROG}$		100		$\mu s$
$t_{RECHARGE}$	Recharge Comparator Filter Time	$V_{BAT}$ High to Low		2		ms
$t_{TERM}$	Termination Comparator Filter Time	$I_{BAT}$ Falling Below $I_{CHG}/10$		1000		$\mu s$
$I_{PROG}$	PROG Pin Pull-Up Current			1		$\mu A$

**Note 1:** Exceeding the absolute maximum rating may damage the device.

**Note 2:** The device is not guaranteed to function outside its operating rating.

**Note 3:** Supply current includes PROG pin current (approximately  $100\mu A$ ) but does not include any current delivered to the battery through the BAT pin (approximately 100mA).

**Note 4:**  $I_{TERM}$  is expressed as a fraction of measured full charge current with indicated PROG resistor.

**Typical Performance Curves**

**Note:** The graphs and tables provided following this note are a statistical summary based on a limited number of samples and are provided for informational purposes only. The performance characteristics listed herein are not tested or guaranteed. In some graphs or tables, the data presented may be outside the specified operating range (e.g., outside specified power supply range) and therefore outside the warranted range.

**Float Voltage vs Supply Voltage**

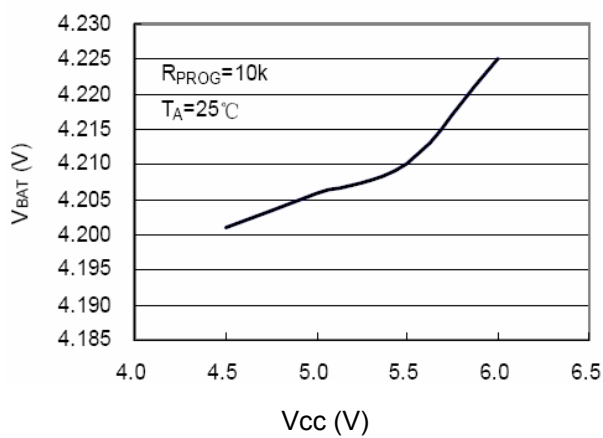

**Charge Current vs Supply Voltage**

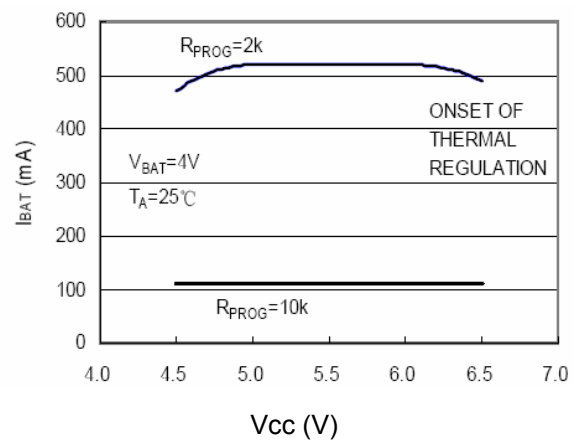

**Trickle Charge Current vs Supply Voltage**

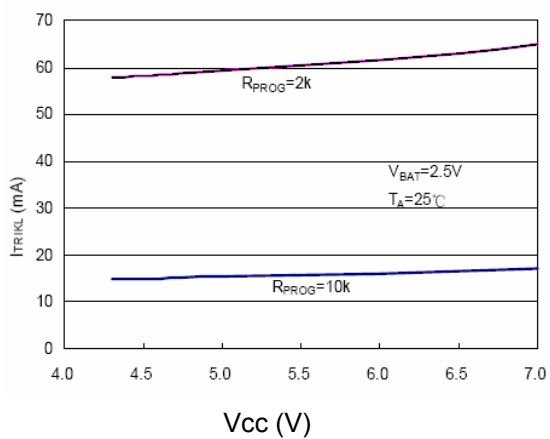

**Float Voltage vs Temperature**

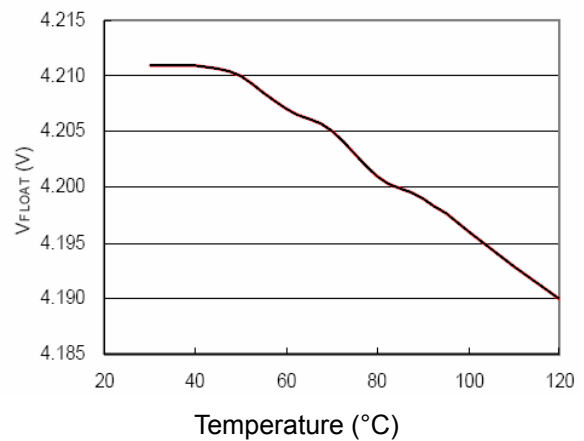

## Operation

The TQ7051 is a single cell lithium-ion battery charger using a constant-current/constant-voltage algorithm. It can deliver up to 800mA of charge current (using a good thermal PCB layout) with a final float voltage accuracy of  $\pm 1\%$ . The TQ7051 includes an internal P-channel power MOSFET and thermal regulation circuitry. No blocking diode or external current sense resistor is required; thus, the basic charger circuit requires only two external components. Furthermore, the TQ7051 is capable of operating from a USB power source.

## Normal Charge Cycle

A charge cycle begins when the voltage at the VCC pin rises above the UVLO threshold level and a 1% program resistor is connected from the PROG pin to ground or when a battery is connected to the charger output. If the BAT pin is less than 2.8V, the charger enters trickle charge mode. In this mode, the TQ7051 supplies approximately 1/10 the programmed charge current to bring the battery voltage up to a safe level for full current charging. When the BAT pin voltage rises above 2.8V, the charger enters constant-current mode, where the programmed charge current is supplied to the battery. When the BAT pin approaches the final float voltage (4.2V), the TQ7051 enters constant-voltage mode and the charge current begins to decrease. When the charge current drops to 1/10 of the programmed value, the charge cycle ends.

## Programming Charge Current

The charge current is programmed using a single resistor from the PROG pin to ground. The battery charge current is 1100 times the current out of the PROG pin. The program resistor and the charge current are calculated using the following

equations:

$$R_{PROG} = \frac{1000V}{I_{CHG}}, I_{CHG} = \frac{1000V}{R_{PROG}}$$

The charge current out of the BAT pin can be determined at any time by monitoring the PROG pin voltage using the following equation:

$$I_{BAT} = \frac{V_{PROG}}{R_{PROG}} \cdot 1000$$

## Charge Termination

A charge cycle is terminated when the charge current falls to 1/10th the programmed value after the final float voltage is reached. This condition is detected by using an internal, filtered comparator to monitor the PROG pin. When the PROG pin voltage falls below 100mV for longer than  $t_{TERM}$  (typically 1ms), charging is terminated. The charge current is latched off and the TQ7051 enters standby mode, where the input supply current drops to 200mA. (Note: C/10 termination is disabled in trickle charging and thermal limiting modes).

When charging, transient loads on the BAT pin can cause the PROG pin to fall below 100mV for short periods of time before the DC charge current has dropped to 1/10th the programmed value. The 1ms filter time ( $t_{TERM}$ ) on the termination comparator ensures that transient loads of this nature do not result in premature charge cycle termination. Once the average charge current drops below 1/10th the programmed value, the TQ7051 terminates the charge cycle and ceases to provide any current through the BAT pin. In this state, all loads on the BAT pin must be supplied by the battery.

The TQ7051 constantly monitors the BAT pin voltage in standby mode. If this voltage drops below the 4.05V recharge threshold ( $V_{RECHRG}$ ), another charge cycle begins and current is once again supplied to the battery. To manually restart a charge cycle when in standby mode, the input voltage must be removed and reapplied, or the

charger must be shut down and restarted using the PROG pin. Figure 1 shows the state diagram of a typical charge cycle.

### Charge Status Indicator (CHRG)

The charge status output has three different states: strong pull-down (~10mA), weak pull-down (~20μA) and high impedance. The strong pull-down state indicates that the TQ7051 is in a charge cycle. Once the charge cycle has terminated, the pin state is determined by undervoltage lockout conditions. A weak pull-down indicates that V<sub>CC</sub> meets the UVLO conditions and the TQ7051 is ready to charge. High impedance indicates that the TQ7051 is in undervoltage lockout mode: either V<sub>CC</sub> is less than 100mV above the BAT pin voltage or insufficient voltage is applied to the V<sub>CC</sub> pin.

### Thermal Limiting

An internal thermal feedback loop reduces the programmed charge current if the die temperature attempts to rise above a preset value of

approximately 120°C. This feature protects the TQ7051 from excessive temperature and allows the user to push the limits of the power handling capability of a given circuit board without risk of damaging the TQ7051. The charge current can be set according to typical (not worst-case) ambient temperature with the assurance that the charger will automatically reduce the current in worst-case conditions. ThinSOT power considerations are discussed further in the Applications Information section.

### Undervoltage Lockout (UVLO)

An internal undervoltage lockout circuit monitors the input voltage and keeps the charger in shutdown mode until V<sub>CC</sub> rises above the undervoltage lockout threshold. The UVLO circuit has a built-in hysteresis of 200mV. Furthermore, to protect against reverse current in the power MOSFET, the UVLO circuit keeps the charger in shutdown mode if V<sub>CC</sub> falls to within 30mV of the battery voltage. If the UVLO comparator is tripped, the charger will not come out of shutdown mode until V<sub>CC</sub> rises 100mV above the battery voltage.

## Application Hints

### Stability Considerations

The constant-voltage mode feedback loop is stable without an output capacitor provided a battery is connected to the charger output. With no battery present, an output capacitor is recommended to reduce ripple voltage. When using high value, low ESR ceramic capacitors, it is recommended to add a 1Ω resistor in series with the capacitor. No series resistor is needed if tantalum capacitors are used.

In constant-current mode, the PROG pin is in the feedback loop, not the battery. The constant-current mode stability is affected by the impedance at the PROG pin. With no additional capacitance on the PROG pin, the charger is stable with program resistor values as high as 20k. However, additional capacitance on this node reduces the maximum allowed program resistor. The pole frequency at the PROG pin should be kept above 100kHz.

### Vcc Bypass Capacitor

Many types of capacitors can be used for input bypassing, however, caution must be exercised when using multilayer ceramic capacitors. Because of the self-resonant and high Q characteristics of some types of ceramic capacitors, high voltage transients can be generated under some start-up conditions, such as connecting the charger input to a live power source. Adding a 1.5Ω resistor in series with a ceramic capacitor will minimize start-up voltage transients.

### Power Dissipation

The conditions that cause the TQ7051 to reduce charge current through thermal feedback can be approximated by considering the power dissipated in the IC. Nearly all of this power dissipation is generated by the internal MOSFET this is calculated to be approximately:

$$P_D = (V_{CC} - V_{BAT}) \cdot I_{BAT}$$

The approximate ambient temperature at which the thermal feedback begins to protect the IC is:

$$T_A = 120^\circ\text{C} - P_D \theta_{JA}$$
$$T_A = 120^\circ\text{C} - (V_{CC} - V_{BAT}) \cdot I_{BAT} \cdot \theta_{JA}$$

### Thermal Considerations

Because of the small size of the thin SOT23 package, it is very important to use a good thermal PC board layout to maximize the available charge current. The thermal path for the heat generated by the IC is from the die to the copper lead frame, through the package leads, (especially the ground lead) to the PC board copper. The PC board copper is the heat sink. The footprint copper pads should be as wide as possible and expand out to larger copper areas to spread and dissipate the heat to the surrounding ambient. Other heat sources on the board, not related to the charger, must also be considered when designing a PC board layout because they will affect overall temperature rise and the maximum charge current.

**Outline Dimension**

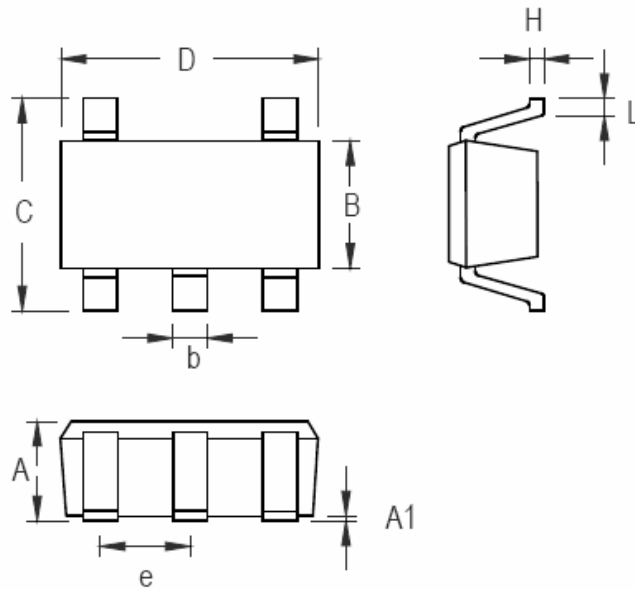

Symbol	Dimensions In Millimeters		Dimensions In Inches	
	Min	Max	Min	Max
A	0.889	1.295	0.035	0.051
A1	0.000	0.152	0.000	0.006
B	1.397	1.803	0.055	0.071
b	0.356	0.559	0.014	0.022
C	2.591	2.997	0.102	0.118
D	2.692	3.099	0.106	0.122
e	0.838	1.041	0.033	0.041
H	0.080	0.254	0.003	0.010
L	0.300	0.610	0.012	0.024

**SOT23 – 5 Package**