

Serial real-time clocks with alarm

Features

- Serial RTC with alarm functions
 - 400 kHz I²C serial interface
 - Memory mapped registers for seconds, minutes, hours, day, date, month, year, and century
 - Tenths/hundredths of seconds register
- 350 nA timekeeping current at 3 V
- Timekeeping down to 1.0 V
- 1.3 V to 4.4 V I²C bus operating voltage
 - 4.4 V max V_{CC} suitable for lithium-ion battery operation
- Low operating current of 35 µA (at 400 kHz)
- 32 KHz square wave output is on at power-up. Suitable for driving a microcontroller in low-power mode. Can be disabled. (M41T62/63/64)
- Programmable 1 Hz to 32 KHz square wave output (M41T62/63/64)
- Programmable alarm with interrupt function (M41T62/65)
- 32 KHz crystal oscillator integrates crystal load capacitors, works with high series resistance crystals
- Oscillator stop detection monitors clock operation
- Accurate programmable watchdog
 - 62.5 ms to 31 min timeout

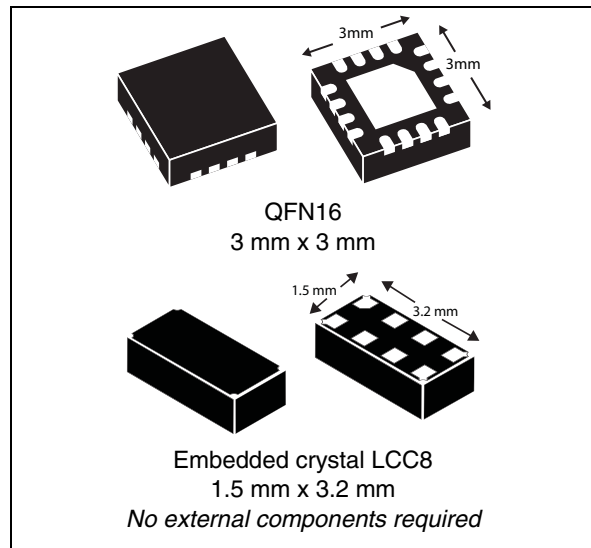

- Software clock calibration. Can adjust timekeeping to within ±2 parts per million (±5 seconds per month)
- Automatic leap year compensation
- –40 to +85 °C operation
- Two package options:
 - Very small 3 mm x 3 mm, lead-free & halogen-free (ECOPACK2[®]) 16-lead QFN
 - Ultra-small 1.5 mm x 3.2 mm, lead-free & halogen-free (ECOPACK2[®]) 8-pin ceramic leadless chip carrier with embedded 32 KHz crystal - no external oscillator components required (M41T62)

Table 1. Device summary

	Basic RTC	Alarms	OSC fail detect	Watchdog timer	Calibration	SQW output	IRQ output	WDO output	F _{32K} output
M41T62	✓	✓	✓	✓	✓	✓	✓		
M41T63 ⁽¹⁾	✓	✓	✓	✓	✓	✓		✓	
M41T64	✓	✓	✓	✓	✓	✓			✓
M41T65	✓	✓	✓	✓	✓		✓	✓	

1. Contact local ST sales office for availability.

Contents

1	Description	6
2	Operation	12
2.1	2-wire bus characteristics	12
2.1.1	Bus not busy	12
2.1.2	Start data transfer	12
2.1.3	Stop data transfer	12
2.1.4	Data valid	13
2.1.5	Acknowledge	13
2.2	READ mode	14
2.3	WRITE mode	16
3	Clock operation	17
3.1	RTC registers	18
3.2	Calibrating the clock	24
3.3	Setting alarm clock registers	26
3.4	Watchdog timer	27
3.5	Watchdog output (WDO - M41T63/65 only)	27
3.6	Square wave output (M41T62/63/64)	28
3.7	Full-time 32 KHz square wave output (M41T64)	28
3.8	Century bits	29
3.9	Output driver pin (M41T62/65)	29
3.10	Oscillator stop detection	29
3.11	Initial power-on defaults	30
4	Maximum ratings	31
5	DC and AC parameters	32
6	Package mechanical information	36
7	Part numbering	41

8 Revision history 42

List of tables

Table 1.	Device summary	1
Table 2.	Signal names	9
Table 3.	M41T62 register map	20
Table 4.	M41T63 register map	21
Table 5.	M41T64 register map	22
Table 6.	M41T65 register map	23
Table 7.	Alarm repeat modes	26
Table 8.	Square wave output frequency	28
Table 9.	Initial power-on default values	30
Table 10.	Century bits examples	30
Table 11.	Absolute maximum ratings	31
Table 12.	Operating and AC measurement conditions	32
Table 13.	Capacitance	33
Table 14.	DC characteristics	33
Table 15.	Crystal electrical characteristics	34
Table 16.	Crystals suitable for use with M41T6x series RTCs	34
Table 17.	Oscillator characteristics	35
Table 18.	AC characteristics	35
Table 19.	QFN16 – 16-pin, quad, flat package, no-lead, 3 mm x 3 mm body size, mechanical data.	37
Table 20.	Carrier tape dimensions for QFN16 3 mm x 3 mm package.	39
Table 21.	Reel dimensions for 12 mm carrier tape - QFN16 and LCC8 packages.	40
Table 22.	Ordering information scheme	41
Table 23.	Document revision history	42

List of figures

Figure 1.	M41T62 logic diagram	6
Figure 2.	M41T63 logic diagram	7
Figure 3.	M41T64 logic diagram	7
Figure 4.	M41T65 logic diagram	7
Figure 5.	M41T62 connections	8
Figure 6.	M41T63 connections	8
Figure 7.	M41T64 connections	8
Figure 8.	M41T65 connections	9
Figure 9.	M41T62 block diagram	9
Figure 10.	M41T63 block diagram	10
Figure 11.	M41T64 block diagram	10
Figure 12.	M41T65 block diagram	10
Figure 13.	Hardware hookup for SuperCap™ backup operation	11
Figure 14.	Serial bus data transfer sequence	13
Figure 15.	Acknowledgement sequence	14
Figure 16.	Slave address location	14
Figure 17.	READ mode sequence	15
Figure 18.	Alternative READ mode sequence	15
Figure 19.	WRITE mode sequence	16
Figure 20.	Buffer/transfer registers	18
Figure 21.	Crystal accuracy across temperature	25
Figure 22.	Calibration waveform	25
Figure 23.	Alarm interrupt reset waveform	26
Figure 24.	AC measurement I/O waveform	32
Figure 25.	Crystal isolation example	32
Figure 26.	Bus timing requirements sequence	35
Figure 27.	QFN16 – 16-pin, quad, flat package, no-lead, 3 mm x 3 mm body size, outline	37
Figure 28.	QFN16 – 16-pin, quad, flat package, no-lead, 3 x 3 mm, recommended footprint	38
Figure 29.	LCC8 — 8-pin 1.5 mm x 3.2 mm leadless chip carrier	38
Figure 30.	Carrier tape for QFN16 3 mm x 3mm package	39
Figure 31.	Carrier tape for LCC8 1.5 mm x 3.2 mm package	39
Figure 32.	Reel schematic	40

1 Description

The M41T6x serial access TIMEKEEPER® is a low power serial RTC with a built-in 32.768 kHz oscillator. Eight registers are used for the clock/calendar function and are configured in binary coded decimal (BCD) format. An additional 8 registers provide status/control of alarm, 32 KHz output, calibration, and watchdog functions. Addresses and data are transferred serially via a two line, bi-directional I²C interface. The built-in address register is incremented automatically after each WRITE or READ data byte.

Functions available to the user include a time-of-day clock/calendar, alarm interrupts (M41T62/65), 32 KHz output (M41T62/63/64), programmable square wave output (M41T62/63/64), and watchdog output (M41T63/65). The eight clock address locations contain the century, year, month, date, day, hour, minute, second and tenths/hundredths of a second in 24 hour BCD format. Corrections for 28-, 29- (leap year), 30- and 31-day months are made automatically.

The M41T6x is supplied in two very small packages: a tiny, 3 mm x 3 mm 16-pin QFN which requires a user-supplied 32 KHz crystal, and an ultra-small 1.5 mm x 3.2 mm LCC with embedded crystal - no external crystal is required.

Figure 1. M41T62 logic diagram

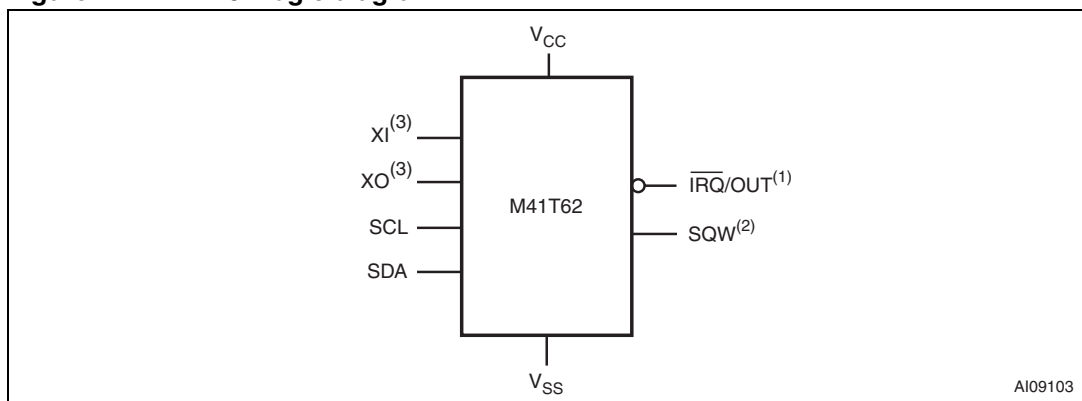

1. Open drain.
2. Defaults to 32 KHz on power-up.
3. Not bonded on LCC package.

Figure 2. M41T63 logic diagram

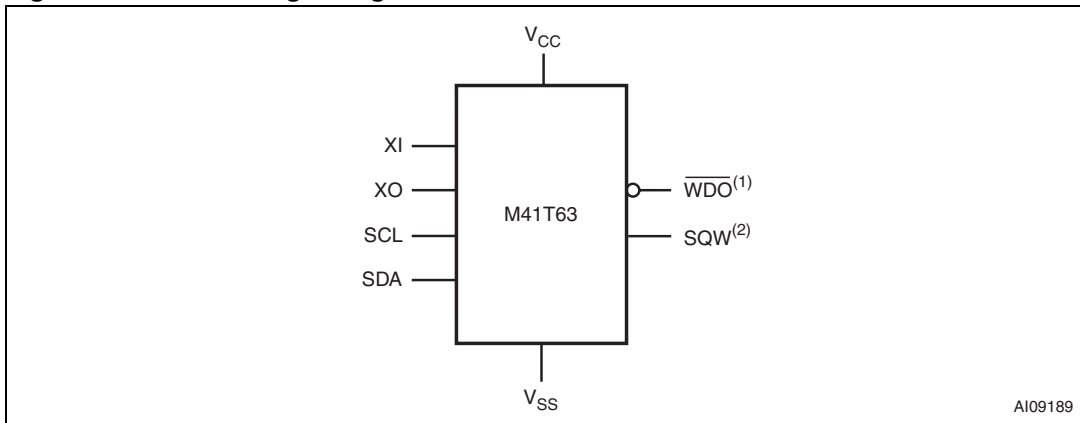

- 1. Open drain.
- 2. Defaults to 32 KHz on power-up.

Figure 3. M41T64 logic diagram

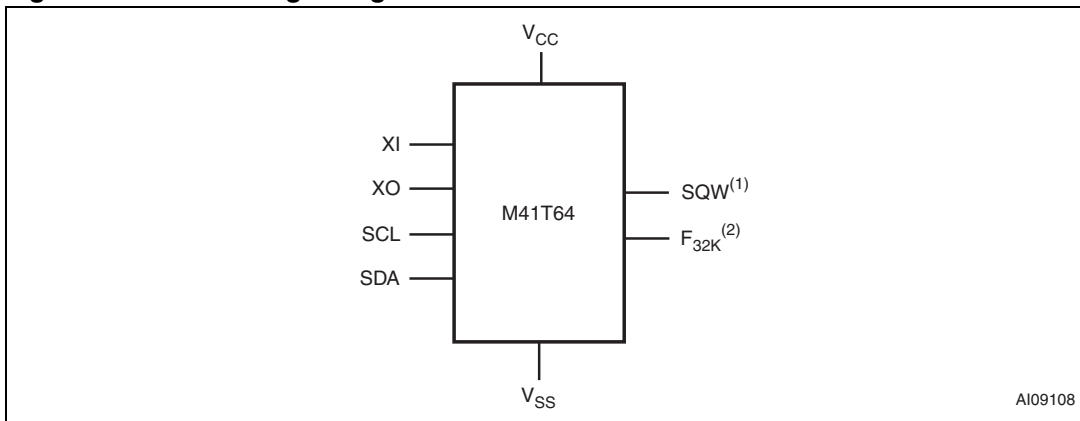

- 1. Open drain.
- 2. Defaults to 32 KHz on power-up.

Figure 4. M41T65 logic diagram

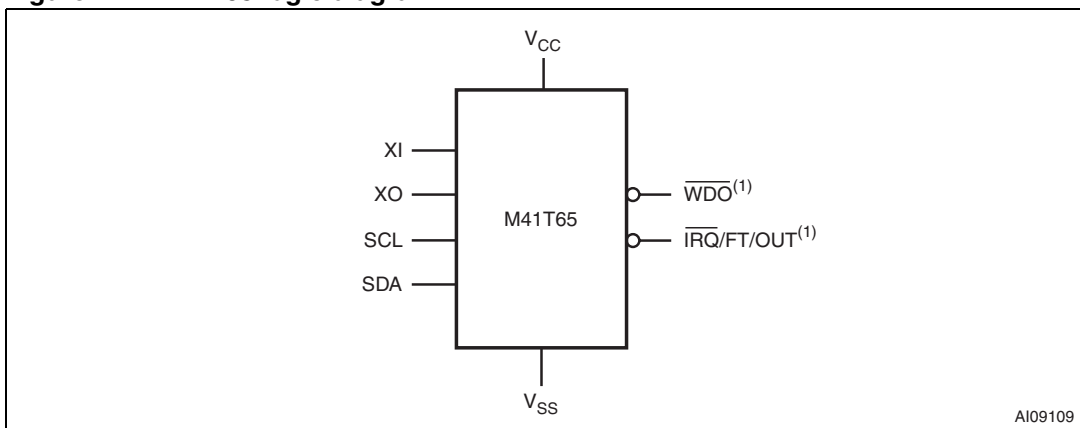

- 1. Open drain.

Figure 5. M41T62 connections

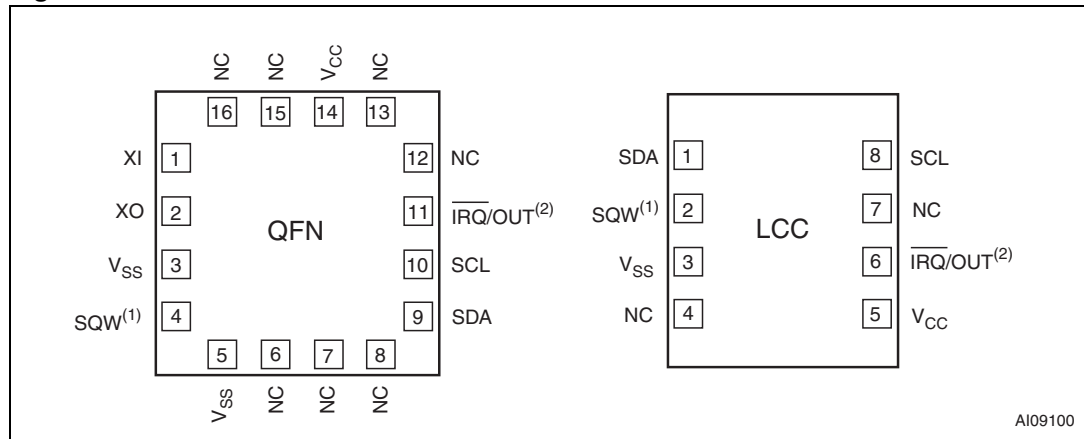

- 1. SQW output defaults to 32 KHz upon power-up.
- 2. Open drain.

Figure 6. M41T63 connections

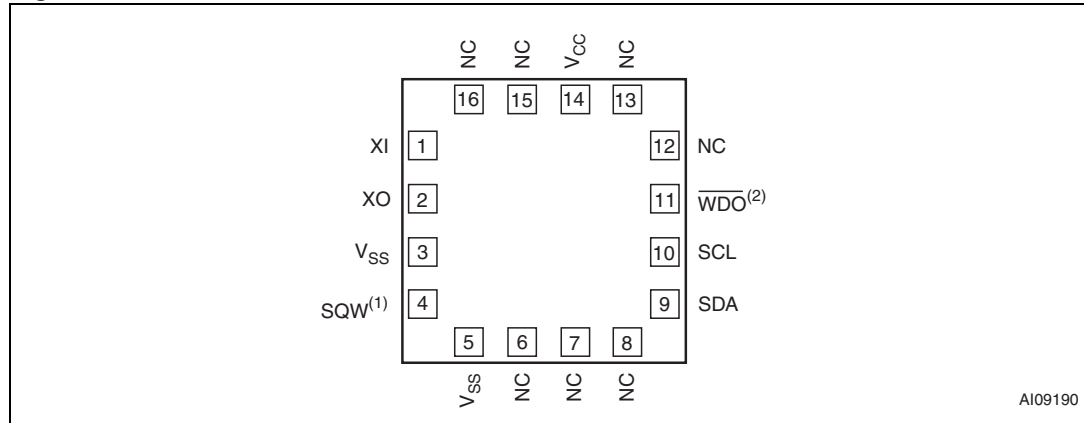

- 1. SQW output defaults to 32 KHz upon power-up.
- 2. Open drain.

Figure 7. M41T64 connections

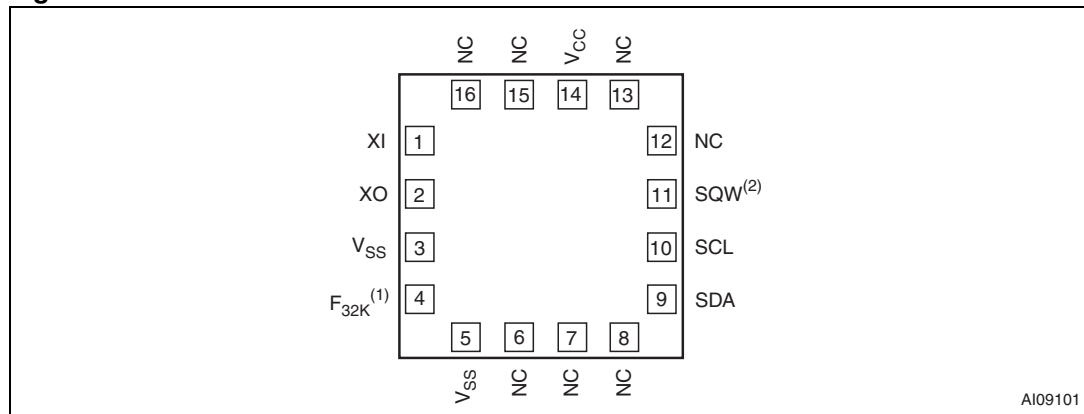

- 1. Enabled on power-up.
- 2. Open drain.

Figure 8. M41T65 connections

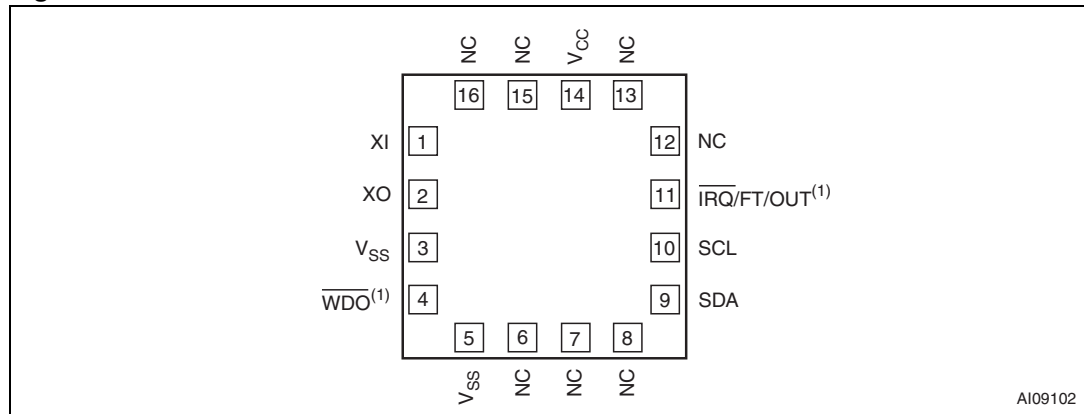

1. Open drain.

Table 2. Signal names

XI	Oscillator input
XO	Oscillator output
SDA	Serial data input/output
SCL	Serial clock input
\overline{IRQ}/OUT	Interrupt or OUT output (open drain)
$\overline{IRQ/FT/OUT}$	Interrupt, frequency test, or OUT output (open drain)
SQW	Programmable square wave - defaults to 32 KHz on power-up (open drain for M41T64 only)
F _{32K}	Dedicated 32 KHz output (M41T64 only)
WDO	Watchdog timer output (open drain)
V _{CC}	Supply voltage
V _{SS}	Ground

Figure 9. M41T62 block diagram

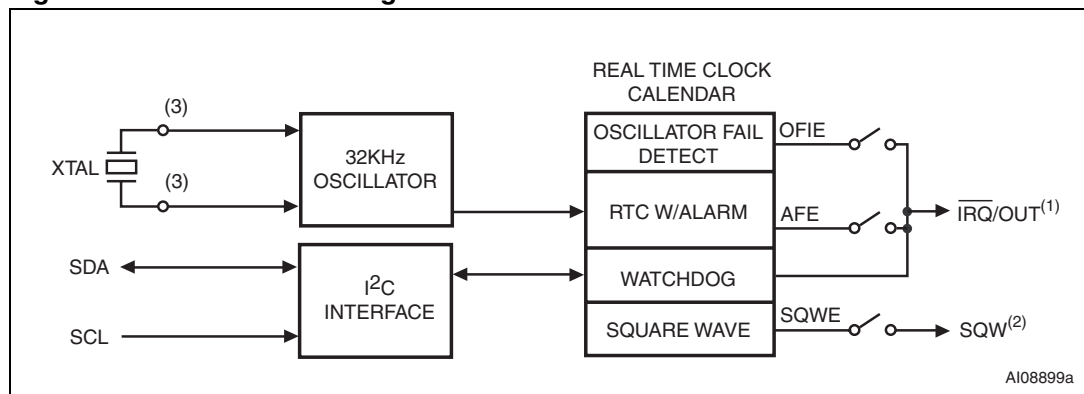

1. Open drain.
2. Defaults to 32 KHz on power-up.
3. Not bonded on embedded crystal (LCC) package.

Figure 10. M41T63 block diagram

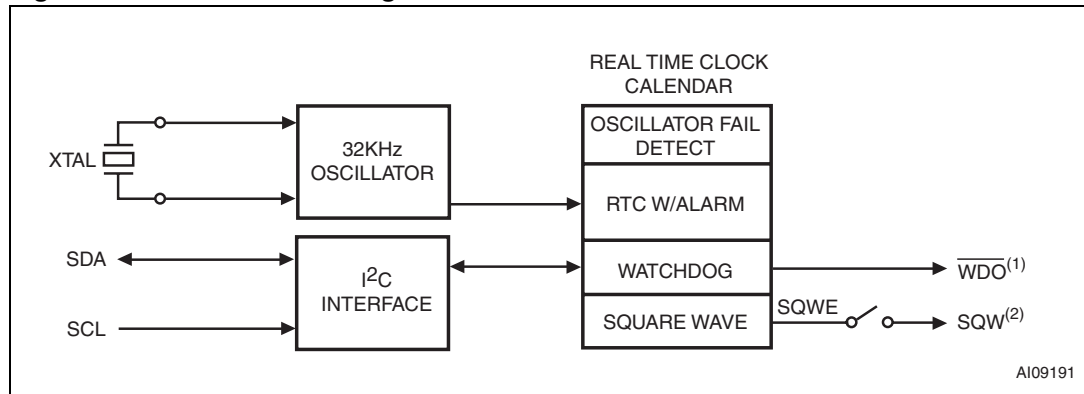

- 1. Open drain.
- 2. Defaults to 32 KHz on power-up.

Figure 11. M41T64 block diagram

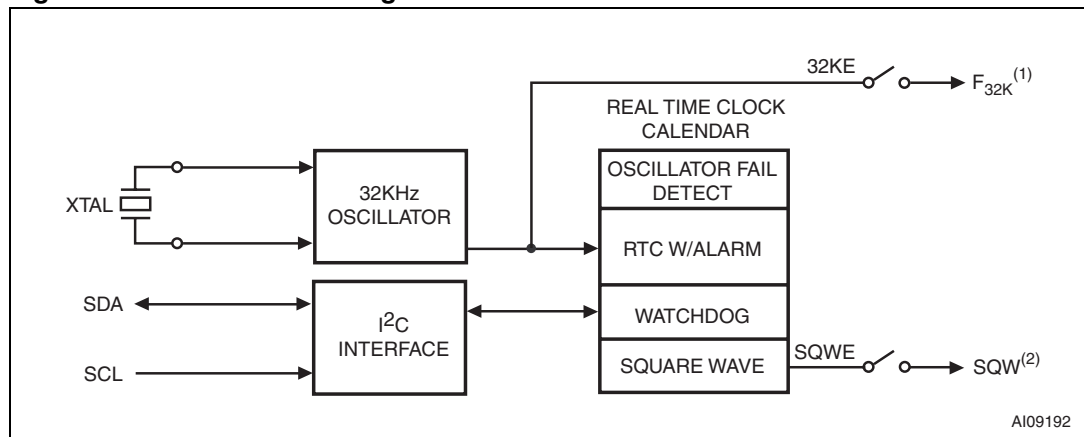

- 1. Defaults enabled on power-up.
- 2. Open drain.

Figure 12. M41T65 block diagram

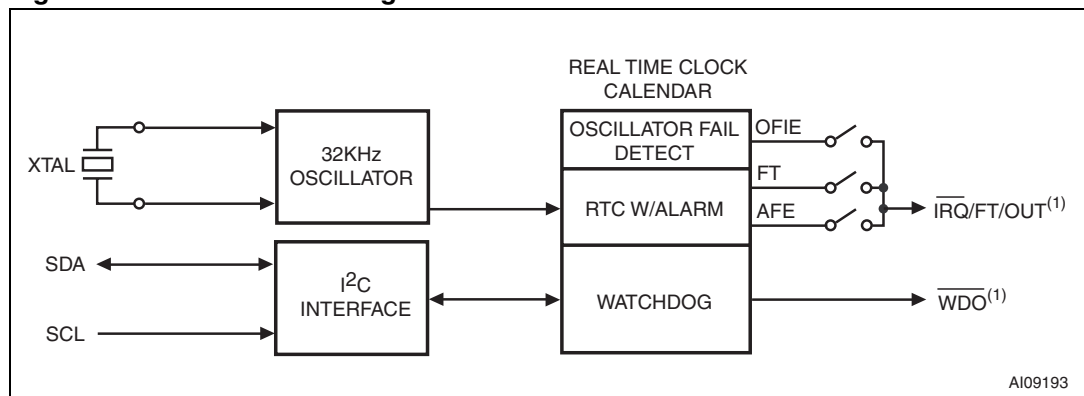

- 1. Open drain.

Figure 13. Hardware hookup for SuperCap™ backup operation

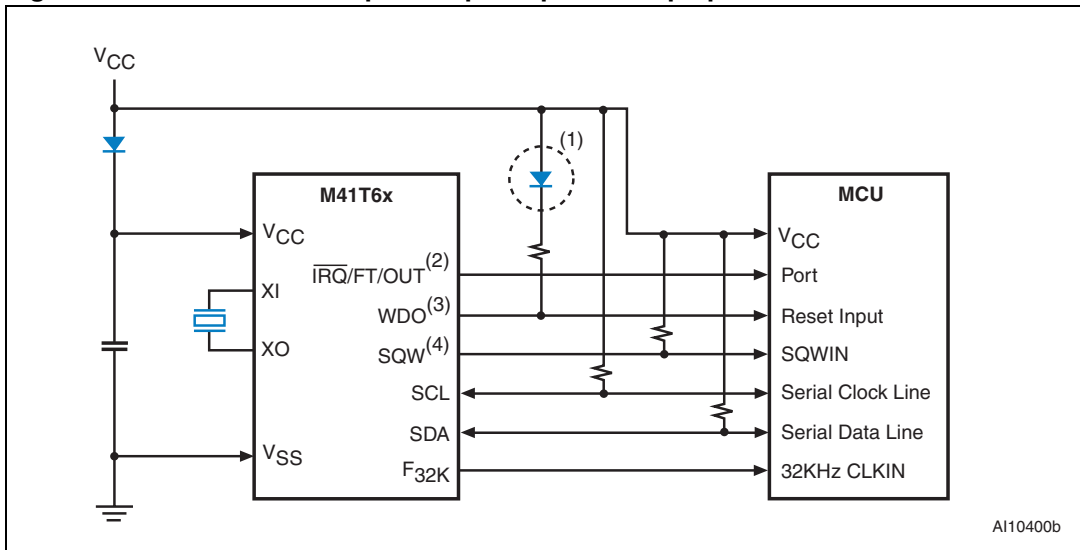

1. Diode required on open drain pin (M41T65 only) for SuperCap (or battery) backup. Low threshold BAT42 diode recommended.
2. For M41T62 and M41T65 (open drain).
3. For M41T63 and M41T65 (open drain).
4. For M41T64 (open drain).

2 Operation

The M41T6x clock operates as a slave device on the serial bus. Access is obtained by implementing a start condition followed by the correct slave address (D0h). The 16 bytes contained in the device can then be accessed sequentially in the following order:

- 1st byte: tenths/hundredths of a second register
- 2nd byte: seconds register
- 3rd byte: minutes register
- 4th byte: hours register
- 5th byte: square wave/day register
- 6th byte: date register
- 7th byte: century/month register
- 8th byte: year register
- 9th byte: calibration register
- 10th byte: watchdog register
- 11th - 15th bytes: alarm registers
- 16th byte: flags register

2.1 2-wire bus characteristics

The bus is intended for communication between different ICs. It consists of two lines: a bi-directional data signal (SDA) and a clock signal (SCL). Both the SDA and SCL lines must be connected to a positive supply voltage via a pull-up resistor.

The following protocol has been defined:

- Data transfer may be initiated only when the bus is not busy.
- During data transfer, the data line must remain stable whenever the clock line is high.
- Changes in the data line, while the clock line is high, will be interpreted as control signals.

Accordingly, the following bus conditions have been defined:

2.1.1 Bus not busy

Both data and clock lines remain high.

2.1.2 Start data transfer

A change in the state of the data line, from high to low, while the clock is high, defines the START condition.

2.1.3 Stop data transfer

A change in the state of the data line, from low to high, while the clock is high, defines the STOP condition.

2.1.4 Data valid

The state of the data line represents valid data when after a start condition, the data line is stable for the duration of the high period of the clock signal. The data on the line may be changed during the Low period of the clock signal. There is one clock pulse per bit of data.

Each data transfer is initiated with a start condition and terminated with a stop condition. The number of data bytes transferred between the start and stop conditions is not limited. The information is transmitted byte-wide and each receiver acknowledges with a ninth bit.

By definition a device that gives out a message is called “transmitter,” the receiving device that gets the message is called “receiver.” The device that controls the message is called “master.” The devices that are controlled by the master are called “slaves.”

2.1.5 Acknowledge

Each byte of eight bits is followed by one acknowledge bit. This acknowledge bit is a low level put on the bus by the receiver whereas the master generates an extra acknowledge related clock pulse. A slave receiver which is addressed is obliged to generate an acknowledge after the reception of each byte that has been clocked out of the slave transmitter.

The device that acknowledges has to pull down the SDA line during the acknowledge clock pulse in such a way that the SDA line is a stable Low during the high period of the acknowledge related clock pulse. Of course, setup and hold times must be taken into account. A master receiver must signal an end of data to the slave transmitter by not generating an acknowledge on the last byte that has been clocked out of the slave. In this case the transmitter must leave the data line high to enable the master to generate the STOP condition.

Figure 14. Serial bus data transfer sequence

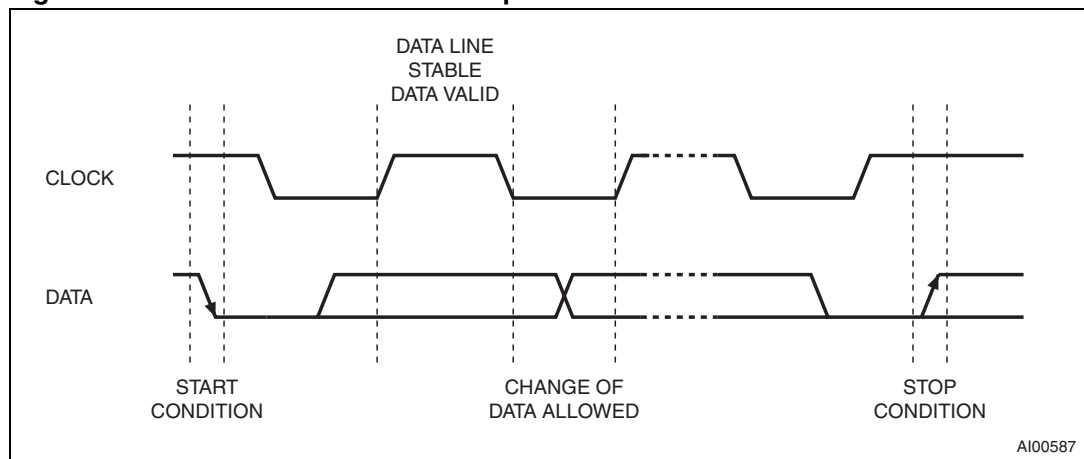
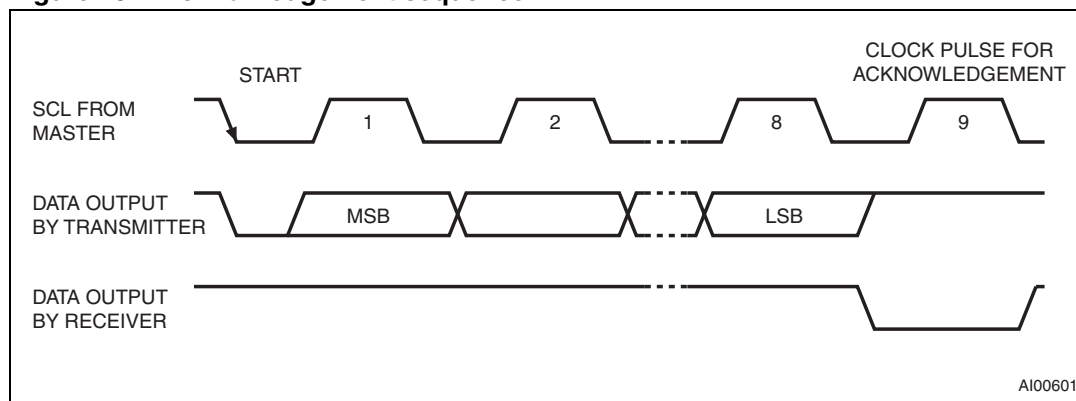

Figure 15. Acknowledgement sequence



2.2 READ mode

In this mode the master reads the M41T6x slave after setting the slave address (see [Figure 17 on page 15](#)). Following the WRITE mode control bit ($R/\bar{W}=0$) and the acknowledge bit, the word address 'An' is written to the on-chip address pointer. Next the START condition and slave address are repeated followed by the READ mode control bit ($R/\bar{W}=1$). At this point the master transmitter becomes the master receiver. The data byte which was addressed will be transmitted and the master receiver will send an acknowledge bit to the slave transmitter. The address pointer is only incremented on reception of an acknowledge clock. The M41T6x slave transmitter will now place the data byte at address An+1 on the bus, the master receiver reads and acknowledges the new byte and the address pointer is incremented to "An+2."

This cycle of reading consecutive addresses will continue until the master receiver sends a STOP condition to the slave transmitter.

The system-to-user transfer of clock data will be halted whenever the address being read is a clock address (00h to 07h). The update will resume due to a stop condition or when the pointer increments to any non-clock address (08h-0Fh).

Note: This is true both in READ mode and WRITE mode.

An alternate READ mode may also be implemented whereby the master reads the M41T6x slave without first writing to the (volatile) address pointer. The first address that is read is the last one stored in the pointer (see [Figure 18 on page 15](#)).

Figure 16. Slave address location

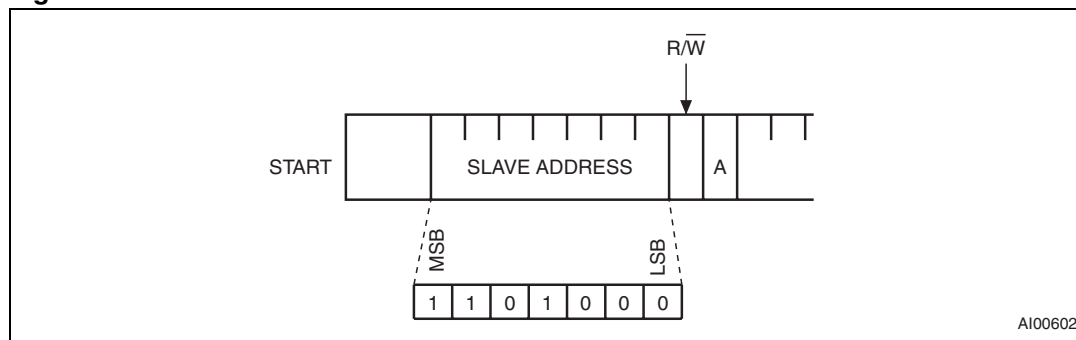
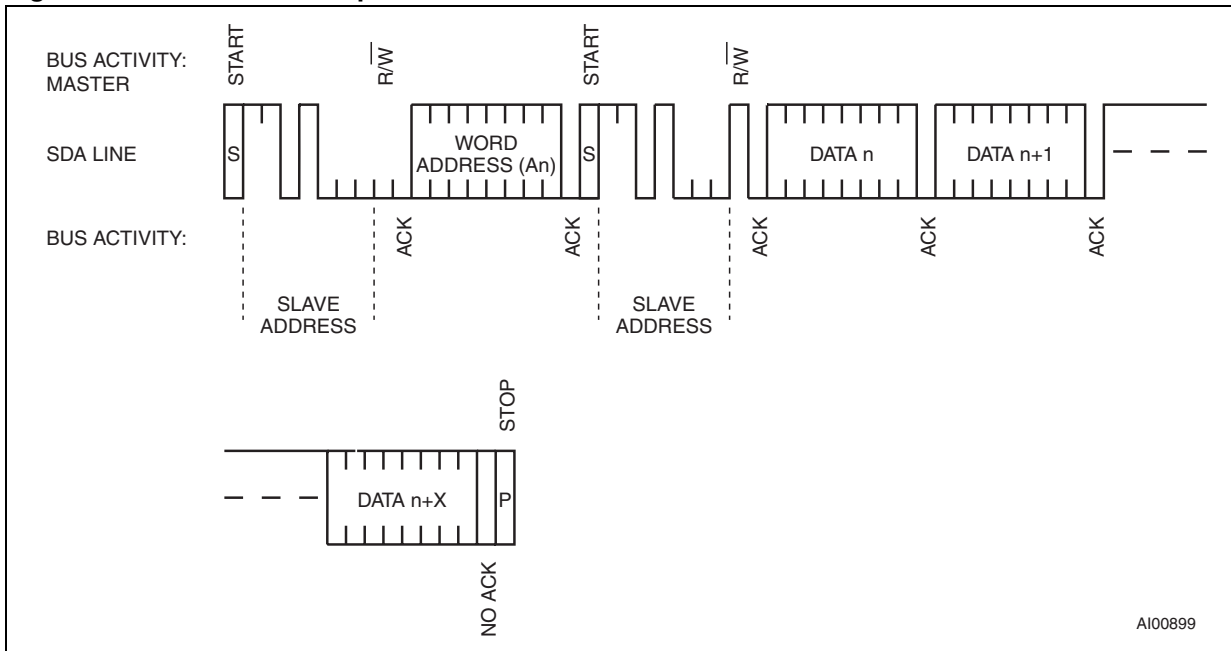
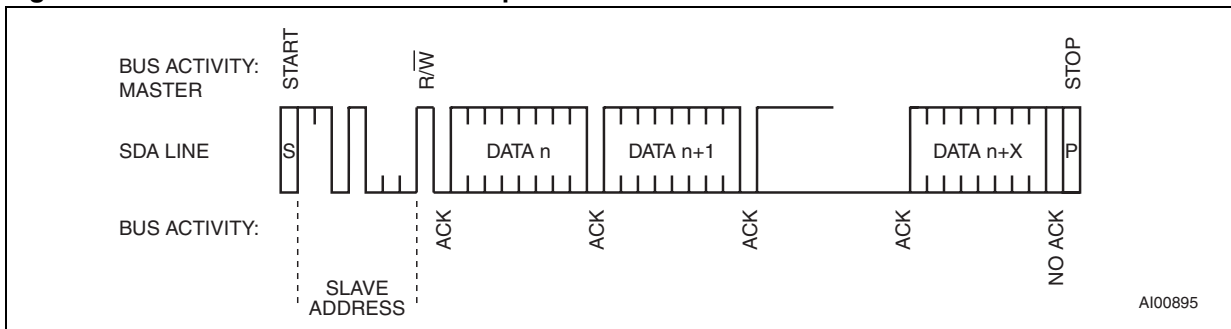

Figure 17. READ mode sequence



AI00899

Figure 18. Alternative READ mode sequence



AI00895

2.3 WRITE mode

In this mode the master transmitter transmits to the M41T6x slave receiver. Bus protocol is shown in *Figure 19 on page 16*. Following the START condition and slave address, a logic '0' ($R/\overline{W}=0$) is placed on the bus and indicates to the addressed device that word address “An” will follow and is to be written to the on-chip address pointer. The data word to be written to the memory is strobed in next and the internal address pointer is incremented to the next address location on the reception of an acknowledge clock. The M41T6x slave receiver will send an acknowledge clock to the master transmitter after it has received the slave address see *Figure 16 on page 14* and again after it has received the word address and each data byte.

Figure 19. WRITE mode sequence

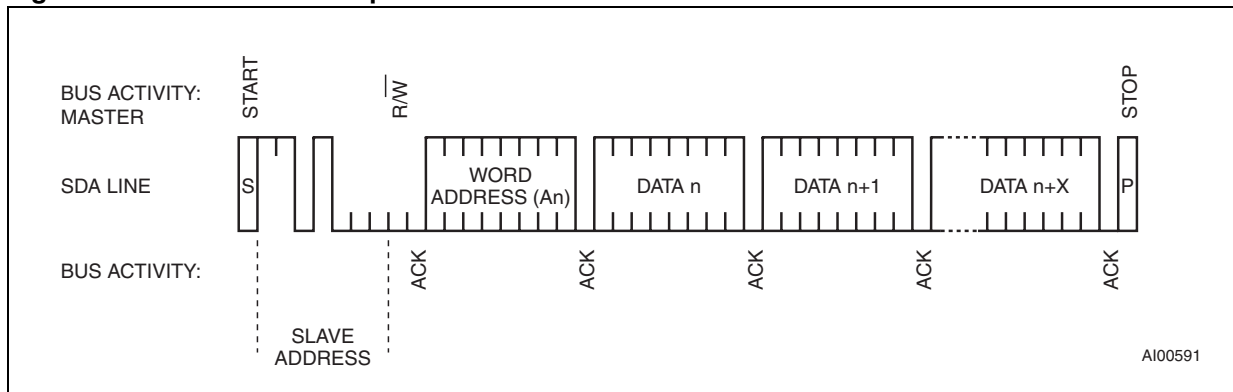

3 Clock operation

The M41T6x is driven by a quartz-controlled oscillator with a nominal frequency of 32.768 kHz. The accuracy of the real-time clock depends on the frequency of the quartz crystal that is used as the time-base for the RTC.

The eight byte clock register (see [Table 3: M41T62 register map](#), [Table 4: M41T63 register map](#), [Table 5: M41T64 register map](#), and [Table 6: M41T65 register map](#)) is used to both set the clock and to read the date and time from the clock, in a binary coded decimal format. Tenths/hundredths of seconds, seconds, minutes, and hours are contained within the first four registers.

A WRITE to any clock register will result in the tenths/hundredths of seconds being reset to “00,” and tenths/hundredths of seconds cannot be written to any value other than “00.”

Bits D0 through D2 of register 04h contain the day (day of week). Registers 05h, 06h, and 07h contain the date (day of month), month, and years. The ninth clock register is the calibration register (this is described in the clock calibration section). Bit D7 of register 01h contains the STOP bit (ST). Setting this bit to a '1' will cause the oscillator to stop. When reset to a '0' the oscillator restarts within one second (typical).

Upon initial power-up, the user should set the ST bit to a '1,' then immediately reset the ST bit to '0.' This provides an additional “kick-start” to the oscillator circuit.

Bit D7 of register 02h (minute register) contains the oscillator fail interrupt enable bit (OFIE). When the user sets this bit to '1,' any condition which sets the oscillator fail bit (OF) (see [Oscillator stop detection on page 29](#)) will also generate an interrupt output.

Bits D6 and D7 of clock register 06h (century/month register) contain the CENTURY bit 0 (CB0) and CENTURY bit 1 (CB1).

A WRITE to ANY location within the first eight bytes of the clock register (00h-07h), including the OFIE bit, RS0-RS3 bit, and CB0-CB1 bits will result in an update of the system clock and a reset of the divider chain. This could result in an inadvertent change of the current time. These non-clock related bits should be written prior to setting the clock, and remain unchanged until such time as a new clock time is also written.

The eight clock registers may be read one byte at a time, or in a sequential block. Provision has been made to assure that a clock update does not occur while any of the eight clock addresses are being read. If a clock address is being read, an update of the clock registers will be halted. This will prevent a transition of data during the READ.

3.1 RTC registers

The M41T6x user interface is comprised of 16 memory mapped registers which include clock, calibration, alarm, watchdog, flags, and square wave control. The eight clock counters are accessed indirectly via a set of buffer/transfer registers while the other eight registers are directly accessed. Data in the clock and alarm registers is in BCD format.

Figure 20. Buffer/transfer registers

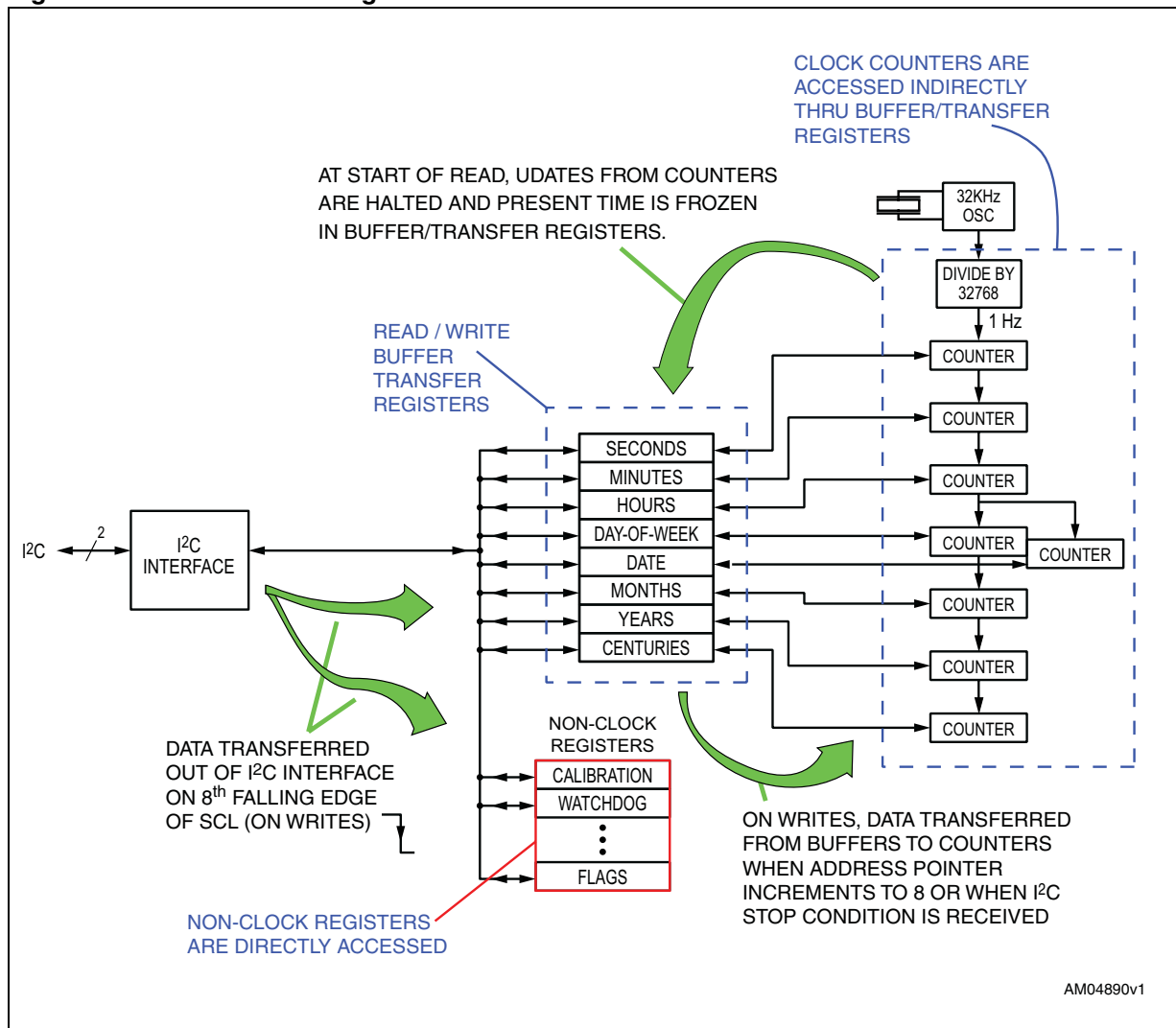

Updates

During normal operation when the user is not accessing the device, the buffer/transfer registers are kept updated with a copy of the RTC counters. At the start of an I²C read or write cycle, the updating is halted and the present time is frozen in the buffer/transfer registers.

Reads of the clock registers

By halting the updates at the start of an I²C access, the user is ensured that all the data transferred out during a read sequence comes from the same instant in time.

Write timing

When writing to the device, the data is shifted into the M41T62's I²C interface on the rising edge of the SCL signal. As shown in [Figure 20](#), on the 8th clock cycle, the data is transferred from the I²C block into whichever register is being pointed to by the address pointer (not shown).

Writes to the clock registers (addresses 0-7)

Data written to the clock registers (addresses 0-7) is held in the buffer registers until the address pointer increments to 8, or an I²C stop condition occurs, at which time the data in the buffer/registers is simultaneously copied into the counters, and then the clock is re-started.

Table 3. M41T62 register map

Addr									Function/range BCD format	
	D7	D6	D5	D4	D3	D2	D1	D0		
00h	0.1 seconds				0.01 seconds				10ths/100ths of seconds	00-99
01h	ST	10 seconds			Seconds				Seconds	00-59
02h	OFIE	10 minutes			Minutes				Minutes	00-59
03h	0	0	10 hours		Hours (24-hour format)				Hours	00-23
04h	RS3	RS2	RS1	RS0	0	Day of week			Day	01-7
05h	0	0	10 date		Date: day of month				Date	01-31
06h	CB1	CB0	0	10M	Month				Century/month	0-3/01-12
07h	10 years				Year				Year	00-99
08h	OUT	0	S	Calibration				Calibration		
09h	RB2	BMB4	BMB3	BMB2	BMB1	BMB0	RB1	RB0	Watchdog	
0Ah	AFE	SQWE	0	AI 10M	Alarm month				AI month	01-12
0Bh	RPT4	RPT5	AI 10 date		Alarm date				AI date	01-31
0Ch	RPT3	0	AI 10 hour		Alarm hour				AI hour	00-23
0Dh	RPT2	Alarm 10 minutes			Alarm minutes				AI min	00-59
0Eh	RPT1	Alarm 10 seconds			Alarm seconds				AI sec	00-59
0Fh	WDF	AF	0	0	0	OF	0	0	Flags	

Keys:
 0 = must be set to '0'
 AF = alarm flag (read only)
 AFE = alarm flag enable flag
 BMB0 - BMB4 = watchdog multiplier bits
 CB0-CB1 = century bits
 OF = oscillator fail bit
 OFIE = oscillator fail interrupt enable bit
 OUT = output level
 RB0 - RB2 = watchdog resolution bits
 RPT1-RPT5 = alarm repeat mode bits
 RS0-RS3 = SQW frequency bits
 S = sign bit
 SQWE = square wave enable bit
 ST = stop bit
 WDF = watchdog flag bit (read only)

Table 4. M41T63 register map

Addr									Function/range BCD format	
	D7	D6	D5	D4	D3	D2	D1	D0		
00h	0.1 seconds				0.01 seconds				10ths/100ths of seconds	00-99
01h	ST	10 seconds			Seconds				Seconds	00-59
02h	0	10 minutes			Minutes				Minutes	00-59
03h	0	0	10 hours		Hours (24-hour format)				Hours	00-23
04h	RS3	RS2	RS1	RS0	0	Day of week			Day	01-7
05h	0	0	10 date		Date: day of month				Date	01-31
06h	CB1	CB0	0	10M	Month				Century/month	0-3/01-12
07h	10 years				Year				Year	00-99
08h	0	0	S	Calibration					Calibration	
09h	RB2	BMB4	BMB3	BMB2	BMB1	BMB0	RB1	RB0	Watchdog	
0Ah	0	SQWE	0	AI 10M	Alarm month				AI Month	01-12
0Bh	RPT4	RPT5	AI 10 date		Alarm date				AI date	01-31
0Ch	RPT3	0	AI 10 hour		Alarm hour				AI hour	00-23
0Dh	RPT2	Alarm 10 minutes			Alarm minutes				AI min	00-59
0Eh	RPT1	Alarm 10 seconds			Alarm seconds				AI sec	00-59
0Fh	WDF	AF	0	0	0	OF	0	0	Flags	

Keys:

0 = must be set to '0'

AF = alarm flag (read only)

BMB0 - BMB4 = watchdog multiplier bits

CB0-CB1 = century bits

OF = oscillator fail bit

RB0 - RB2 = watchdog resolution bits

RPT1-RPT5 = alarm repeat mode bits

RS0-RS3 = SQW frequency bits

S = sign bit

SQWE = square wave enable bit

ST = stop bit

WDF = watchdog flag bit (read only)

Table 5. M41T64 register map

Addr									Function/range BCD format	
	D7	D6	D5	D4	D3	D2	D1	D0		
00h	0.1 seconds				0.01 seconds				10ths/100ths of seconds	00-99
01h	ST	10 seconds			Seconds				Seconds	00-59
02h	0	10 minutes			Minutes				Minutes	00-59
03h	0	0	10 hours		Hours (24-hour format)				Hours	00-23
04h	RS3	RS2	RS1	RS0	0	Day of week			Day	01-7
05h	0	0	10 Date		Date: day of month				Date	01-31
06h	CB1	CB0	0	10M	Month				Century/month	0-3/01-12
07h	10 years				Year				Year	00-99
08h	0	0	S	Calibration					Calibration	
09h	RB2	BMB4	BMB3	BMB2	BMB1	BMB0	RB1	RB0	Watchdog	
0Ah	0	SQWE	32KE	AI 10M	Alarm month				AI month	01-12
0Bh	RPT4	RPT5	AI 10 date		Alarm date				AI date	01-31
0Ch	RPT3	0	AI 10 hour		Alarm hour				AI hour	00-23
0Dh	RPT2	Alarm 10 minutes			Alarm minutes				AI min	00-59
0Eh	RPT1	Alarm 10 seconds			Alarm seconds				AI sec	00-59
0Fh	WDF	AF	0	0	0	OF	0	0	Flags	

Keys:

- 0 = must be set to '0'
- 32KE = 32 KHz enable bit
- AF = alarm flag (read only)
- BMB0 - BMB4 = watchdog multiplier bits
- CB0-CB1 = century bits
- OF = oscillator fail bit
- RB0 - RB2 = watchdog resolution bits
- RPT1-RPT5 = alarm repeat mode bits
- RS0-RS3 = SQW frequency bits
- S = sign bit
- SQWE = square wave enable bit
- ST = stop bit
- WDF = watchdog flag bit (read only)

Table 6. M41T65 register map

Addr									Function/range BCD format	
	D7	D6	D5	D4	D3	D2	D1	D0		
00h	0.1 seconds				0.01 seconds				10ths/100ths of seconds	00-99
01h	ST	10 seconds			Seconds				Seconds	00-59
02h	OFIE	10 minutes			Minutes				Minutes	00-59
03h	0	0	10 hours		Hours (24-hour format)				Hours	00-23
04h	0	0	0	0	0	Day of week			Day	01-7
05h	0	0	10 date		Date: day of month				Date	01-31
06h	CB1	CB0	0	10M	Month				Century/month	0-3/01-12
07h	10 years				Year				Year	00-99
08h	OUT	FT	S	Calibration					Calibration	
09h	RB2	BMB4	BMB3	BMB2	BMB1	BMB0	RB1	RB0	Watchdog	
0Ah	AFE	0	0	AI 10M	Alarm month				AI month	01-12
0Bh	RPT4	RPT5	AI 10 date		Alarm date				AI date	01-31
0Ch	RPT3	0	AI 10 hour		Alarm hour				AI hour	00-23
0Dh	RPT2	Alarm 10 minutes			Alarm minutes				AI min	00-59
0Eh	RPT1	Alarm 10 seconds			Alarm seconds				AI sec	00-59
0Fh	WDF	AF	0	0	0	OF	0	0	Flags	

Keys:

0 = must be set to '0'

AF = alarm flag (read only)

AFE = alarm flag enable flag

BMB0 - BMB4 = watchdog multiplier bits

CB0-CB1 = century bits

FT = frequency test bit

OF = oscillator fail bit

OFIE = oscillator fail interrupt enable bit

OUT = output level

RB0 - RB2 = watchdog resolution bits

RPT1-RPT5 = alarm repeat mode bits

S = sign bit

ST = stop bit

WDF = watchdog flag bit (read only)

3.2 Calibrating the clock

The M41T6x real-time clock is driven by a quartz controlled oscillator with a nominal frequency of 32,768 Hz. This provides the time-base for the RTC. The accuracy of the clock depends on the frequency accuracy of the crystal, and the match between the capacitive load of the oscillator circuit and the capacitive load for which the crystal was trimmed. The M41T6x oscillator is designed for use with a 6 - 7 pF crystal load capacitance. When the calibration circuit is properly employed, accuracy improves to better than ± 2 ppm at 25 °C.

The oscillation rate of crystals changes with temperature (see [Figure 21 on page 25](#)). Therefore, the M41T6x design employs periodic counter correction. The calibration circuit adds or subtracts counts from the oscillator divider circuit at the divide by 256 stage, as shown in [Figure 22 on page 25](#). The number of times pulses which are blanked (subtracted, negative calibration) or split (added, positive calibration) depends upon the value loaded into the five calibration bits found in the calibration register. Adding counts speeds the clock up, subtracting counts slows the clock down.

The calibration bits occupy the five lower order bits (D4-D0) in the calibration register (08h). These bits can be set to represent any value between 0 and 31 in binary form. Bit D5 is a sign bit; '1' indicates positive calibration, '0' indicates negative calibration. Calibration occurs within a 64 minute cycle. The first 62 minutes in the cycle may, once per minute, have one second either shortened by 128 or lengthened by 256 oscillator cycles. If a binary '1' is loaded into the register, only the first 2 minutes in the 64 minute cycle will be modified; if a binary 6 is loaded, the first 12 will be affected, and so on.

Therefore, each calibration step has the effect of adding 512 or subtracting 256 oscillator cycles for every 125,829,120 actual oscillator cycles, that is +4.068 or -2.034 ppm of adjustment per calibration step in the calibration register.

Assuming that the oscillator is running at exactly 32,768 Hz, each of the 31 increments in the calibration byte would represent +10.7 or -5.35 seconds per day which corresponds to a total range of +5.5 or -2.75 minutes per month (see [Figure 22 on page 25](#)).

Two methods are available for ascertaining how much calibration a given M41T6x may require:

- The first involves setting the clock, letting it run for a month and comparing it to a known accurate reference and recording deviation over a fixed period of time. Calibration values, including the number of seconds lost or gained in a given period, can be found in application note AN934, "TIMEKEEPER[®] calibration." This allows the designer to give the end user the ability to calibrate the clock as the environment requires, even if the final product is packaged in a non-user serviceable enclosure. The designer could provide a simple utility that accesses the calibration byte.
- The second approach is better suited to a manufacturing environment, and involves the use of either the SQW pin (M41T62/63/64) or the $\overline{\text{IRQ}}/\text{FT}/\text{OUT}$ pin (M41T65). The SQW pin will toggle at 512 Hz when RS3 = '0,' RS2 = '1,' RS1 = '1,' RS0 = '0,' SQWE = '1,' and ST = '0.' Alternatively, for the M41T65, the $\overline{\text{IRQ}}/\text{FT}/\text{OUT}$ pin will toggle at 512 Hz when FT and OUT bits = '1' and ST = '0.'

Any deviation from 512 Hz indicates the degree and direction of oscillator frequency shift at the test temperature. For example, a reading of 512.010124 Hz would indicate a +20 ppm oscillator frequency error, requiring a -10 (XX001010) to be loaded into the calibration byte for correction. Note that setting or changing the calibration byte does not affect the frequency test or square wave output frequency.

Figure 21. Crystal accuracy across temperature

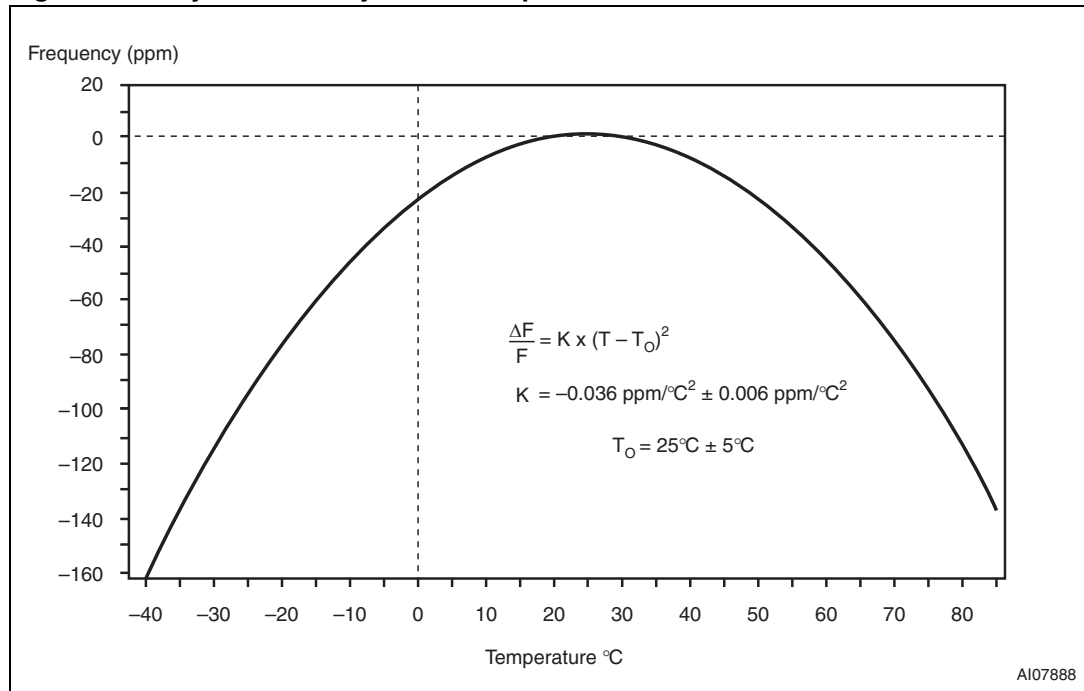
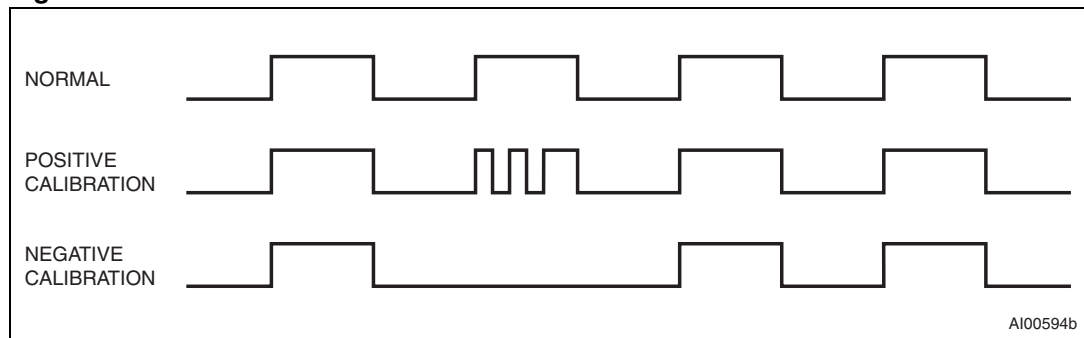

Figure 22. Calibration waveform



3.3 Setting alarm clock registers

Address locations 0Ah-0Eh contain the alarm settings. The alarm can be configured to go off at a prescribed time on a specific month, date, hour, minute, or second, or repeat every year, month, day, hour, minute, or second. Bits RPT5–RPT1 put the alarm in the repeat mode of operation. [Table 7 on page 26](#) shows the possible configurations. Codes not listed in the table default to the once per second mode to quickly alert the user of an incorrect alarm setting.

When the clock information matches the alarm clock settings based on the match criteria defined by RPT5–RPT1, the AF (alarm flag) is set. If AFE (alarm flag enable) is also set (M41T62/65), the alarm condition activates the $\overline{\text{IRQ}}/\text{OUT}$ or $\overline{\text{IRQ}}/\text{FT}/\text{OUT}$ pin. To disable the alarm, write '0' to the alarm date register and to RPT5–RPT1.

Note: If the address pointer is allowed to increment to the flag register address, an alarm condition will not cause the interrupt/flag to occur until the address pointer is moved to a different address. It should also be noted that if the last address written is the "Alarm Seconds," the address pointer will increment to the flag address, causing this situation to occur.

The $\overline{\text{IRQ}}$ output is cleared by a READ to the flags register as shown in [Figure 23 on page 26](#). A subsequent READ of the flags register is necessary to see that the value of the alarm flag has been reset to '0.'

Figure 23. Alarm interrupt reset waveform

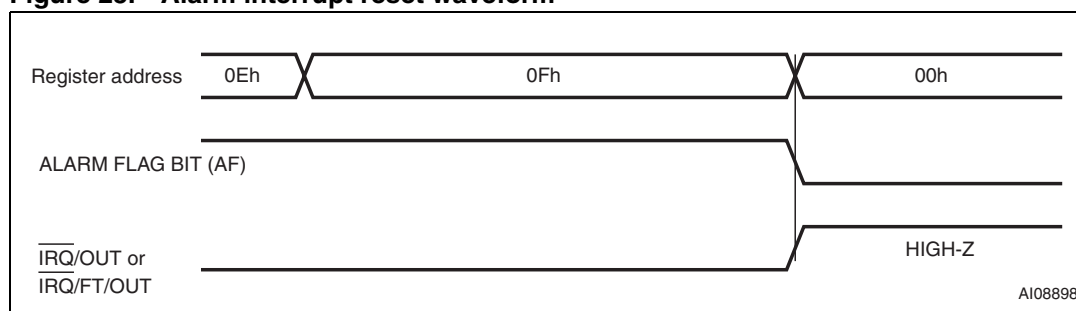

Table 7. Alarm repeat modes

RPT5	RPT4	RPT3	RPT2	RPT1	Alarm setting
1	1	1	1	1	Once per second
1	1	1	1	0	Once per minute
1	1	1	0	0	Once per hour
1	1	0	0	0	Once per day
1	0	0	0	0	Once per month
0	0	0	0	0	Once per year

3.4 Watchdog timer

The watchdog timer can be used to detect an out-of-control microprocessor. The user programs the watchdog timer by setting the desired amount of time-out into the watchdog register, address 09h.

Bits BMB4-BMB0 store a binary multiplier and the three bits RB2-RB0 select the resolution where:

000=1/16 second (16 Hz);

001=1/4 second (4 Hz);

010=1 second (1 Hz);

011=4 seconds (1/4 Hz); and

100 = 1 minute (1/60 Hz).

Note: Invalid combinations (101, 110, and 111) will NOT enable a watchdog time-out. Setting BMB4-BMB0 = 00000 with any combination of RB2-RB0, other than 000, will result in an immediate watchdog time-out.

The amount of time-out is then determined to be the multiplication of the five-bit multiplier value with the resolution. (For example: writing 00001110 in the watchdog register = 3×1 or 3 seconds). If the processor does not reset the timer within the specified period, the M41T6x sets the WDF (watchdog flag) and generates an interrupt on the $\overline{\text{IRQ}}$ pin (M41T62), or a watchdog output pulse (M41T63 and M41T65 only) on the $\overline{\text{WDO}}$ pin. The watchdog timer can only be reset by having the microprocessor perform a WRITE of the watchdog register. The time-out period then starts over.

Should the watchdog timer time-out, any value may be written to the watchdog register in order to clear the $\overline{\text{IRQ}}$ pin. A value of 00h will disable the watchdog function until it is again programmed to a new value. A READ of the flags register will reset the watchdog flag (bit D7; register 0Fh). The watchdog function is automatically disabled upon power-up, and the watchdog register is cleared.

Note: A WRITE to any clock register will restart the watchdog timer.

3.5 Watchdog output ($\overline{\text{WDO}}$ - M41T63/65 only)

If the processor does not reset the watchdog timer within the specified period, the watchdog output ($\overline{\text{WDO}}$) will pulse low for t_{rec} (see [Table 18 on page 35](#)). This output may be connected to the reset input of the processor in order to generate a processor reset. After a watchdog time-out occurs, the timer will remain disabled until such time as a new countdown value is written into the watchdog register.

Note: The crystal oscillator must be running for the $\overline{\text{WDO}}$ pulse to be available.

The $\overline{\text{WDO}}$ output is an N-channel, open drain output driver (with I_{OL} as specified in [Table 14 on page 33](#)).

3.6 Square wave output (M41T62/63/64)

The M41T62/63/64 offers the user a programmable square wave function which is output on the SQW pin. RS3-RS0 bits located in 04h establish the square wave output frequency. These frequencies are listed in [Table 8](#). Once the selection of the SQW frequency has been completed, the SQW pin can be turned on and off under software control with the square wave enable bit (SQWE) located in register 0Ah.

The SQW output is an N-channel, open drain output driver for the M41T64, and a full CMOS output driver for the M41T62/63. The initial power-up default for the SQW output is 32 KHz (except for M41T64, which defaults disabled).

Table 8. Square wave output frequency

Square wave bits				Square wave	
RS3	RS2	RS1	RS0	Frequency	Units
0	0	0	0	None	–
0	0	0	1	32.768	kHz
0	0	1	0	8.192	kHz
0	0	1	1	4.096	kHz
0	1	0	0	2.048	kHz
0	1	0	1	1.024	kHz
0	1	1	0	512	Hz
0	1	1	1	256	Hz
1	0	0	0	128	Hz
1	0	0	1	64	Hz
1	0	1	0	32	Hz
1	0	1	1	16	Hz
1	1	0	0	8	Hz
1	1	0	1	4	Hz
1	1	1	0	2	Hz
1	1	1	1	1	Hz

3.7 Full-time 32 KHz square wave output (M41T64)

The M41T64 offers the user a special 32 KHz square wave function which is enabled on power-up to output on the F_{32K} pin as long as V_{CC} ≥ 1.3 V, and the oscillator is running (ST bit = '0'). This function is available within one second (typ) of initial power-up and can only be disabled by setting the 32KE bit to '0' or the ST bit to '1.' If not used, the F_{32K} pin should be disconnected and allowed to float.

3.8 Century bits

These two bits will increment in a binary fashion at the turn of the century, and handle all leap years correctly. See [Table 10 on page 30](#) for additional explanation.

3.9 Output driver pin (M41T62/65)

When the OFIE bit, AFE bit, and watchdog register are not set to generate an interrupt, the $\overline{\text{IRQ}}/\text{OUT}$ pin becomes an output driver that reflects the contents of D7 of the calibration register. In other words, when D7 (OUT bit) is a '0,' then the $\overline{\text{IRQ}}/\text{OUT}$ pin will be driven low.

Note: The $\overline{\text{IRQ}}/\text{OUT}$ pin is an open drain which requires an external pull-up resistor.

3.10 Oscillator stop detection

If the oscillator fail (OF) bit is internally set to a '1,' this indicates that the oscillator has either stopped, or was stopped for some period of time and can be used to judge the validity of the clock and date data. This bit will be set to '1' any time the oscillator stops.

In the event the OF bit is found to be set to '1' at any time other than the initial power-up, the STOP bit (ST) should be written to a '1,' then immediately reset to '0.' This will restart the oscillator.

The following conditions can cause the OF bit to be set:

- The first time power is applied (defaults to a '1' on power-up).

Note: If the OF bit cannot be written to '0' four (4) seconds after the initial power-up, the STOP bit (ST) should be written to a '1,' then immediately reset to '0.'

- The voltage present on V_{CC} or battery is insufficient to support oscillation.
- The ST bit is set to '1.'
- External interference of the crystal

If the oscillator fail interrupt enable bit (OFIE) is set to a '1,' the $\overline{\text{IRQ}}$ pin will also be activated. The $\overline{\text{IRQ}}$ output is cleared by resetting the OFIE or OF bit to '0' (NOT by reading the flag register).

The OF bit will remain set to '1' until written to logic '0.' The oscillator must start and have run for at least 4 seconds before attempting to reset the OF bit to '0.' If the trigger event occurs during a power-down condition, this bit will be set correctly.

3.11 Initial power-on defaults

Upon application of power to the device, the register bits will initially power-on in the state indicated in [Table 9](#).

Table 9. Initial power-on default values

Condition	Device	ST	OF	OFIE	OUT	FT	AFE	SQWE	32KE	RS3-1	RS0	Watchdog
Initial power-up ⁽¹⁾	M41T62	0	1	0	1	N/A	0	1	N/A	0	1	0
	M41T63	0	1	N/A	N/A	N/A	N/A	1	N/A	0	1	0
	M41T64	0	1	N/A	N/A	N/A	N/A	0	1	0	1	0
	M41T65	0	1	0	1	0	0	N/A	N/A	N/A	N/A	0

1. All other control bits power up in an undetermined state.

Table 10. Century bits examples

CB0	CB1	Leap year?	Example ⁽¹⁾
0	0	Yes	2000
0	1	No	2100
1	0	No	2200
1	1	No	2300

1. Leap year occurs every four years (for years evenly divisible by four), except for years evenly divisible by 100. The only exceptions are those years evenly divisible by 400 (the year 2000 was a leap year, year 2100 is not).

4 Maximum ratings

Stressing the device above the rating listed in the absolute maximum ratings table may cause permanent damage to the device. These are stress ratings only and operation of the device at these or any other conditions above those indicated in the operating sections of this specification is not implied. Exposure to absolute maximum rating conditions for extended periods may affect device reliability.

Table 11. Absolute maximum ratings

Sym	Parameter	Conditions ⁽¹⁾	Value ⁽²⁾	Unit
T _{STG}	Storage temperature (V _{CC} off, oscillator off)		–55 to 125	°C
V _{CC}	Supply voltage		–0.3 to 5.0	V
T _{SLD} ⁽³⁾	Lead solder temperature for 10 seconds		260	°C
V _{IO}	Input or output voltages		–0.2 to V _{CC} +0.3	V
I _O	Output current		20	mA
P _D	Power dissipation		1	W
V _{ESD(HBM)}	Electro-static discharge voltage (human body model)	T _A = 25 °C	>1500	V
V _{ESD(RCDM)}	Electro-static discharge voltage (robotic charged device model)	T _A = 25 °C	>1000	V

1. Test conforms to JEDEC standard.
2. Data based on characterization results, not tested in production.
3. Reflow at peak temperature of 260 °C. The time above 255 °C must not exceed 30 seconds.

5 DC and AC parameters

This section summarizes the operating and measurement conditions, as well as the DC and AC characteristics of the device. The parameters in the following DC and AC characteristic tables are derived from tests performed under the measurement conditions listed in the relevant tables. Designers should check that the operating conditions in their projects match the measurement conditions when using the quoted parameters.

Table 12. Operating and AC measurement conditions⁽¹⁾

Parameter	M41T6x
Supply voltage (V_{CC})	1.3 V to 4.4 V
Ambient operating temperature (T_A)	-40 to 85 °C
Load capacitance (C_L)	50 pF
Input rise and fall times	≤ 5 ns
Input pulse voltages	0.2 V_{CC} to 0.8 V_{CC}
Input and output timing ref. voltages	0.3 V_{CC} to 0.7 V_{CC}

1. Output Hi-Z is defined as the point where data is no longer driven.

Figure 24. AC measurement I/O waveform

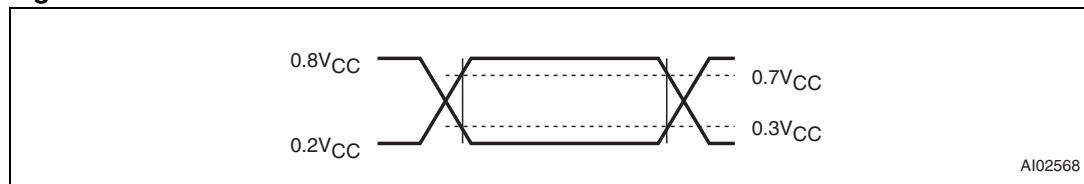
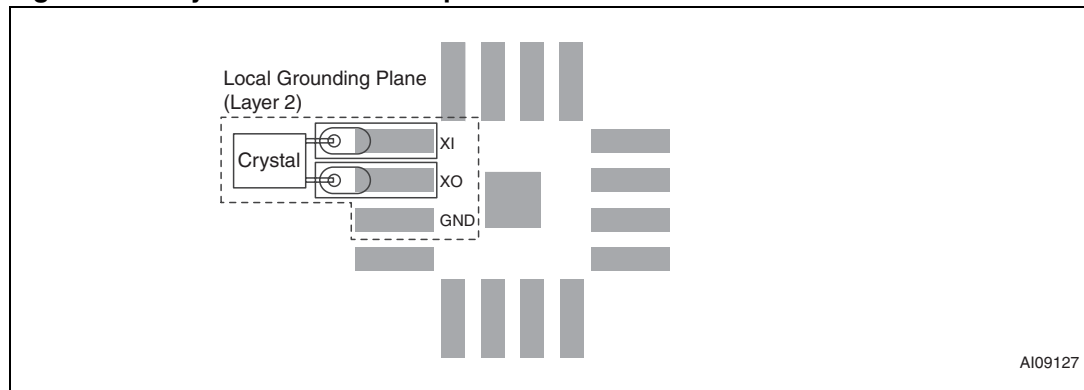

Figure 25. Crystal isolation example



Note: Substrate pad should be tied to V_{SS} .

Table 13. Capacitance

Symbol	Parameter ⁽¹⁾⁽²⁾	Min	Max	Unit
C_{IN}	Input capacitance	-	7	pF
$C_{OUT}^{(3)}$	Output capacitance	-	10	pF
t_{LP}	Low-pass filter input time constant (SDA and SCL)	-	50	ns

1. Effective capacitance measured with power supply at 3.6 V; sampled only, not 100% tested.
2. At 25°C, f = 1 MHz.
3. Outputs deselected.

Table 14. DC characteristics

Sym	Parameter	Test condition ⁽¹⁾		Min	Typ	Max	Unit
$V_{CC}^{(2)}$	Operating voltage	Clock		1.0		4.4	V
		I^2C bus (400 kHz)		1.3		4.4	V
I_{CC1}	Supply current	SCL = 400 kHz (no load)		4.4 V		100	μA
				3.6 V	50	70	μA
				3.0 V	35		μA
				2.5 V	30		μA
				2.0 V	20		μA
I_{CC2}	Supply current (standby)	SCL = 0 Hz all inputs $\geq V_{CC} - 0.2 V$ $\leq V_{SS} + 0.2 V$	SQW off	4.4 V		950	nA
				3.6 V	375	700	nA
				3.0 V at 25 °C	350		nA
				2.0 V at 25 °C	310		nA
V_{IL}	Input low voltage			-0.2		0.3 V_{CC}	V
V_{IH}	Input high voltage			0.7 V_{CC}		$V_{CC} + 0.3$	V
V_{OL}	Output low voltage	$V_{CC} = 4.4 V, I_{OL} = 3.0 mA$ (CMOS or open drain)				0.4	V
		$V_{CC} = 4.4 V, I_{OL} = 1.0 mA$ (SQW, \overline{WDO} , \overline{IRQ})				0.4	V
V_{OH}	Output high voltage	$V_{CC} = 4.4 V, I_{OH} = -1.0 mA$ (push-pull)		2.4			V
	Pull-up supply voltage (open drain)	$\overline{IRQ}/OUT, \overline{IRQ}/FT/OUT, \overline{WDO}, SQW$ (M41T64 only)				4.4	V
I_{LI}	Input leakage current	$0 V \leq V_{IN} \leq V_{CC}$				± 1	μA
I_{LO}	Output leakage current	$0 V \leq V_{OUT} \leq V_{CC}$				± 1	μA

1. Valid for ambient operating temperature: $T_A = -40$ to 85 °C; $V_{CC} = 1.3 V$ to $4.4 V$ (except where noted).
2. Oscillator startup guaranteed at 1.5 V only.

Table 15. Crystal electrical characteristics

Sym	Parameter ⁽¹⁾⁽²⁾	Min	Typ	Max	Units
f_0	Resonant frequency	-	32.768		kHz
R_S	Series resistance ($T_A = -40$ to 70 °C, oscillator startup at 2.0 V)	-		75 ⁽³⁾⁽⁴⁾	k Ω
C_L	Load capacitance	-	6		pF

- For the QFN16 package, user-supplied external crystals are required. The 6 and 7 pF crystals listed in [Table 16](#) below have been evaluated by ST and have been found to be satisfactory for use with the M41T6x series RTC.
- Load capacitors are integrated within the M41T6x. Circuit board layout considerations for the 32.768 kHz crystal of minimum trace lengths and isolation from RF generating signals should be taken into account.
- Guaranteed by design.
- $R_{S(max)} = 65$ k Ω for $T_A = -40$ to 85 °C and oscillator startup at 1.5 V.

Table 16. Crystals suitable for use with M41T6x series RTCs

Vendor	Order number	Package	Manufacturer's specifications			
			ESR max	Temp. range (°C)	Rated tolerance at 25 °C	Rated load cap.
Citizen	CMJ206T-32.768KDZB-UB	8.3 x 2.5 mm leaded SMT	50 k Ω	-40/+85	±20 ppm	6 pF
Citizen	CM315-32.768KDZY-UB	3.2 x 1.5 x 0.9 mm SMT	70 k Ω	-40/+85	±20 ppm	7 pF
Ecliptek	E4WCDA06-32.768K	2.0 x 6.0 mm thru-hole	50 k Ω	-10/+60	±20 ppm	6 pF
Ecliptek	E5WSDC 07 - 32.768K	7 x 1.5 x 1.4 mm SMT	65 k Ω	-40/+85	±20 ppm	7 pF
ECS	ECS-.327-6-17X-TR	3.8 x 8.5 x 2.5 mm SMT	50 k Ω	-10/+60	±20 ppm	6 pF
ECS	ECS-.327-7-34B-TR	3.2 x 1.5 x 0.9 mm SMT	70 k Ω	-40/+85	±20 ppm	7 pF
ECS	ECS-.327-7-38-TR	7 x 1.5 x 1.4 mm SMT	65 k Ω	-40/+85	±20 ppm	7 pF
Epson	MC-146 32.7680KA-AG: ROHS ⁽¹⁾	7 x 1.5 x 1.4 mm SMT	65 k Ω	-40/+85	±20 ppm	7 pF
Fox	298LF-0.032768-19	1.5 x 5.0 mm thru-hole	50 k Ω	-20/+60	±20 ppm	6 pF
Fox	299LF-0.032768-37	2.0 x 6.0 mm thru-hole	50 k Ω	-20/+60	±20 ppm	6 pF
Fox	414LF-0.032768-12	3.8 x 8.5 x 2.5 mm SMT	50 k Ω	-40/+85	±20 ppm	6 pF
Fox	501LF-0.032768-5	7 x 1.5 x 1.4 mm SMT	65 k Ω	-40/+85	±20 ppm	7 pF
Micro Crystal	MS3V-T1R 32.768KHZ 7PF 20PPM	6.7 x 1.4 mm leaded SMT	65 k Ω	-40/+85	±20 ppm	7 pF
Pletronics	SM20S - 32.768K - 6pF	3.8 x 8.5 x 2.5 mm SMT	50 k Ω	-40/+85	±20 ppm	6 pF
Seiko	SSPT7F-7PF20PPM	7 x 1.5 x 1.4 mm SMT	65 k Ω	-40/+85	±20 ppm	7 pF
Seiko	VT200F-6PF20PPM	2.0 x 6.0 mm thru-hole	50 k Ω	-10/+60	±20 ppm	6 pF

- Epson MC-146 32.7680KA-E: ROHS is 6 pF version.

Table 17. Oscillator characteristics

Symbol	Parameter	Conditions	Min	Typ	Max	Unit
V_{STA}	Oscillator start voltage	≤ 10 seconds	1.5			V
t_{STA}	Oscillator start time	$V_{CC} = 3.0$ V			1	s
C_g	XIN capacitance			12		pF
C_d	XOUT capacitance			12		pF
	IC-to-IC frequency variation ⁽¹⁾⁽²⁾		-10		+10	ppm

- Reference value. $T_A = 25$ °C, $V_{CC} = 3.0$ V, CMJ-145 ($C_L = 6$ pF, 32,768 Hz) manufactured by Citizen, $C_L = C_g \cdot C_d / (C_g + C_d)$.
- Devices in LCC8 package ((M41T62LC6F) are tested not to exceed ± 20 ppm oscillator frequency error at 25 °C, which equates to about 52 seconds per month.

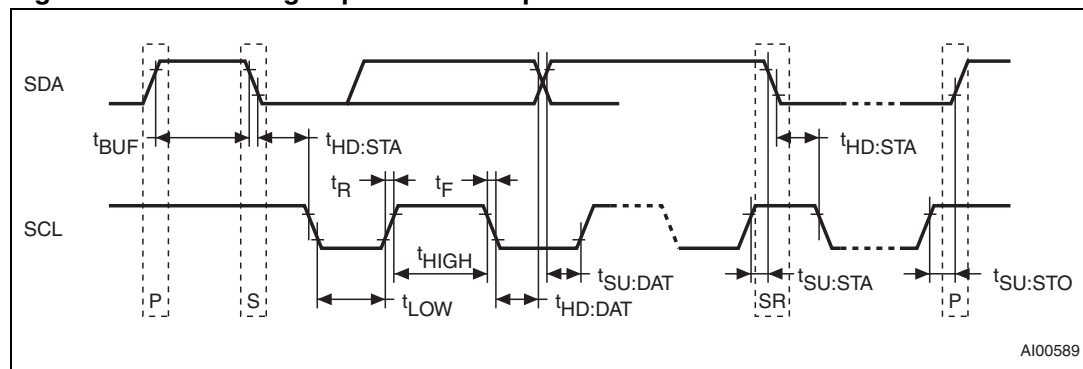
Figure 26. Bus timing requirements sequence**Table 18. AC characteristics**

Sym	Parameter ⁽¹⁾	Min	Max	Units
f_{SCL}	SCL clock frequency	0	400	kHz
t_{LOW}	Clock low period	1.3		μ s
t_{HIGH}	Clock high period	600		ns
t_R	SDA and SCL rise time		300	ns
t_F	SDA and SCL fall time		300	ns
$t_{HD:STA}$	START condition hold time (after this period the first clock pulse is generated)	600		ns
$t_{SU:STA}$	START condition setup time (only relevant for a repeated start condition)	600		ns
$t_{SU:DAT}^{(2)}$	Data setup time	100		ns
$t_{HD:DAT}$	Data hold time	0		μ s
$t_{SU:STO}$	STOP condition setup time	600		ns
t_{BUF}	Time the bus must be free before a new transmission can start	1.3		μ s
t_{rec}	Watchdog output pulse width	96	98	ms

- Valid for ambient operating temperature: $T_A = -40$ to 85 °C; $V_{CC} = 1.3$ to 4.4 V (except where noted).
- Transmitter must internally provide a hold time to bridge the undefined region (300 ns max) of the falling edge of SCL.

6 Package mechanical information

In order to meet environmental requirements, ST offers these devices in different grades of ECOPACK[®] packages, depending on their level of environmental compliance. ECOPACK[®] specifications, grade definitions and product status are available at: www.st.com. ECOPACK[®] is an ST trademark.

Figure 27. QFN16 – 16-pin, quad, flat package, no-lead, 3 mm x 3 mm body size, outline

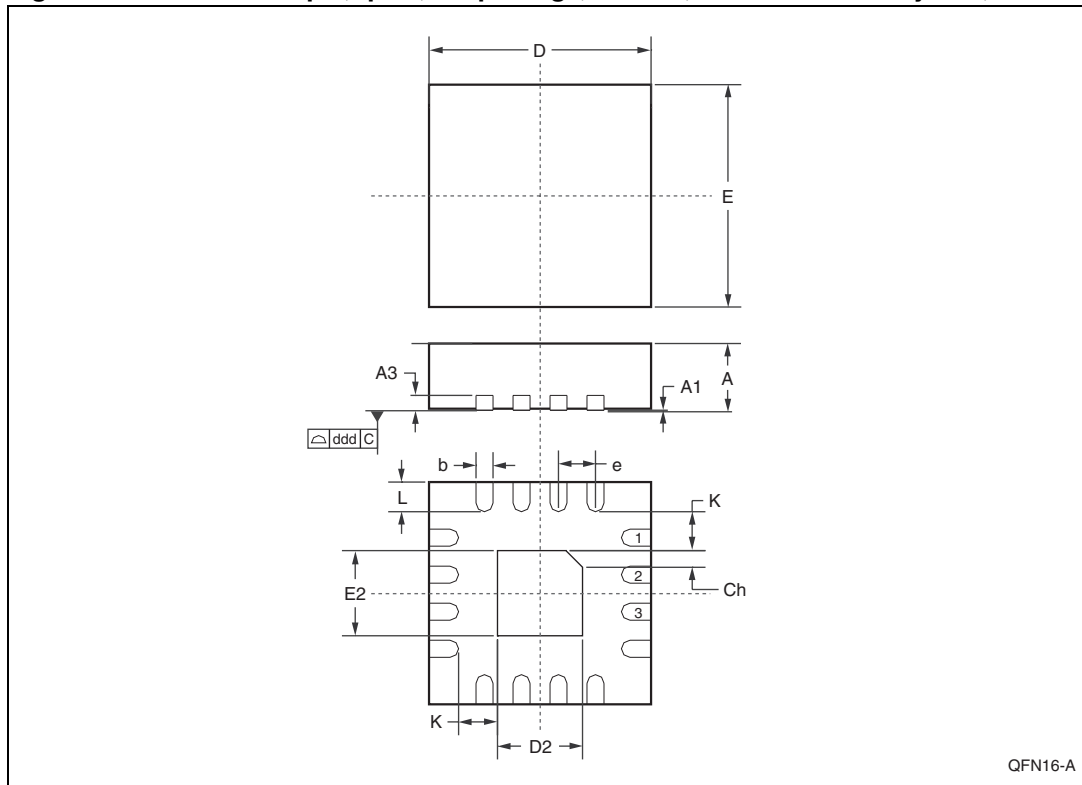

Note: Drawing is not to scale.

Table 19. QFN16 – 16-pin, quad, flat package, no-lead, 3 mm x 3 mm body size, mechanical data

Symb	mm			inches		
	Typ	Min	Max	Typ	Min	Max
A	0.90	0.80	1.00	0.035	0.032	0.039
A1	0.02	0.00	0.05	0.001	0.000	0.002
A3	0.20	–	–	0.008	–	–
b	0.25	0.18	0.30	0.010	0.007	0.012
D	3.00	2.90	3.10	0.118	0.114	0.122
D2	1.70	1.55	1.80	0.067	0.061	0.071
E	3.00	2.90	3.10	0.118	0.114	0.122
E2	1.70	1.55	1.80	0.067	0.061	0.071
e	0.50	–	–	0.020	–	–
K	0.20	–	–	0.008	–	–
L	0.40	0.30	0.50	0.016	0.012	0.020
ddd	–	0.08	–	–	0.003	–
Ch	–	0.33	–	–	0.013	–
N	16			16		

Figure 28. QFN16 – 16-pin, quad, flat package, no-lead, 3 x 3 mm, recommended footprint

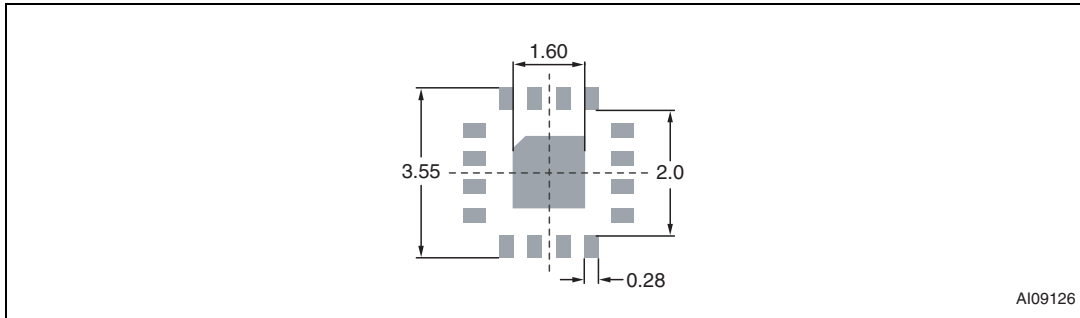

AI09126

Note: Dimensions shown are in millimeters (mm).

Figure 29. LCC8 – 8-pin 1.5 mm x 3.2 mm leadless chip carrier

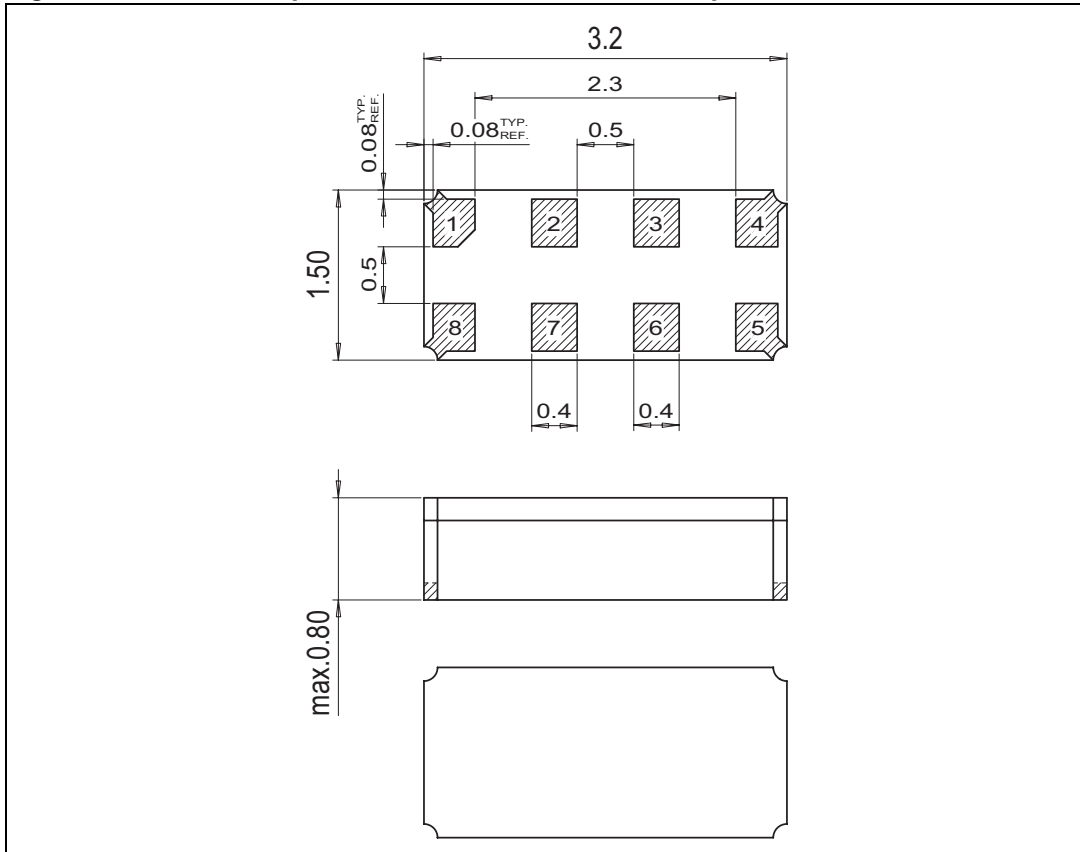

Note: Dimensions shown are in millimeters (mm).

Figure 30. Carrier tape for QFN16 3 mm x 3mm package

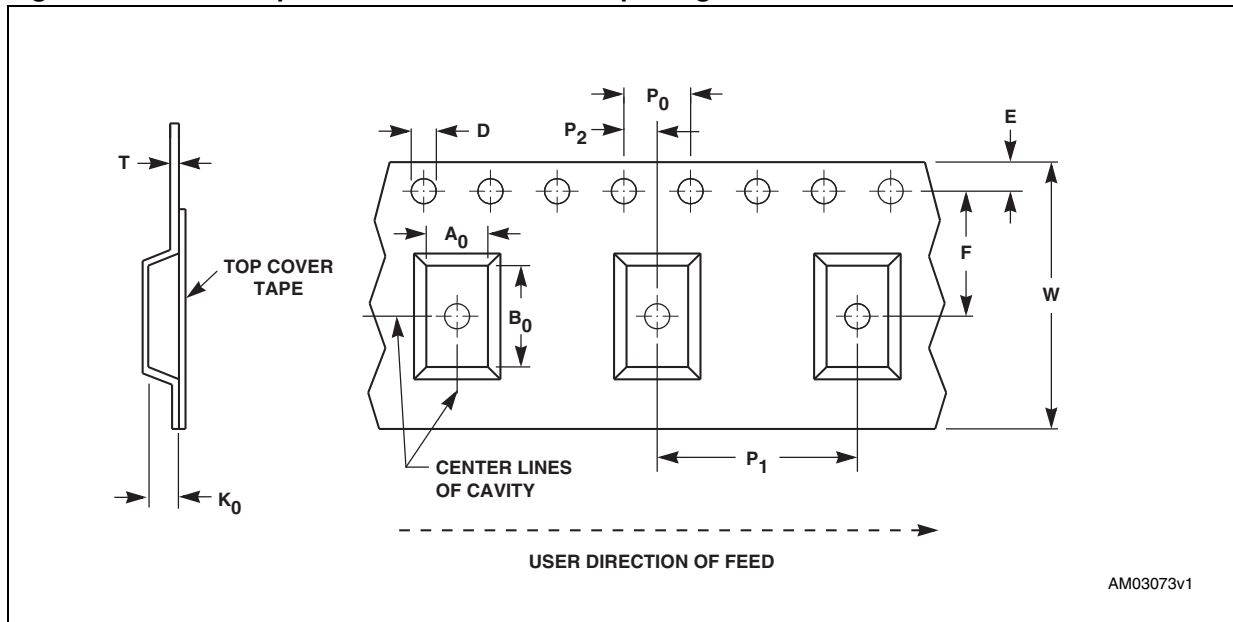
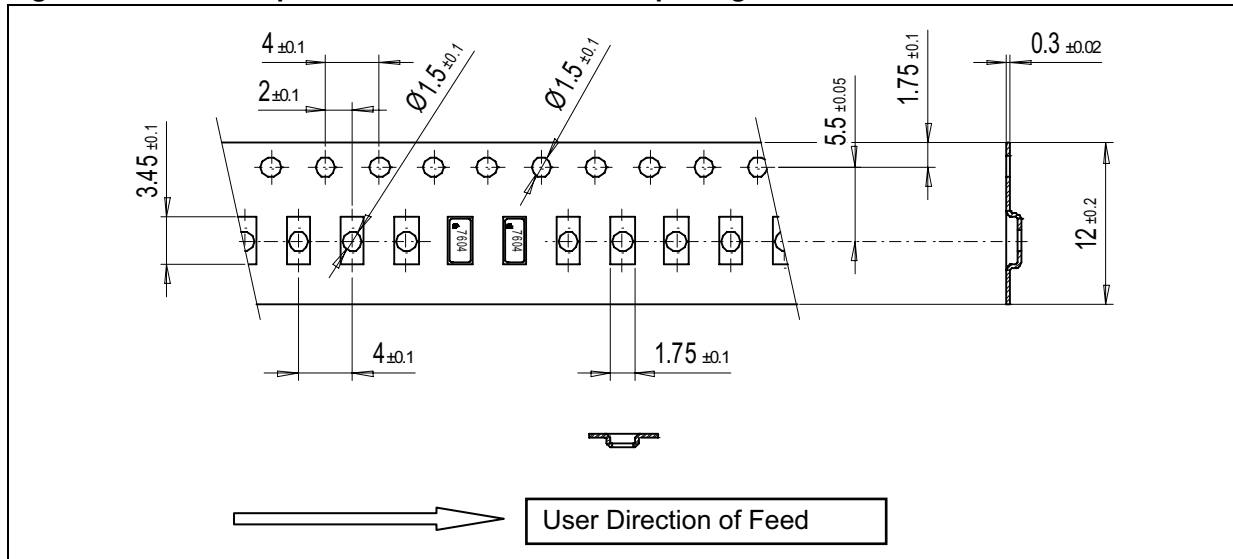

Table 20. Carrier tape dimensions for QFN16 3 mm x 3 mm package

Package	W	D	E	P ₀	P ₂	F	A ₀	B ₀	K ₀	P ₁	T	Unit	Bulk Qty
QFN16	12.00 ±0.30	1.50 +0.10 /-0.00	1.75 ±0.10	4.00 ±0.10	2.00 ±0.10	5.50 ±0.05	3.30 ±0.10	3.30 ±0.10	1.10 ±0.10	8.00 ±0.10	0.30 ±0.05	mm	3000

Figure 31. Carrier tape for LCC8 1.5 mm x 3.2 mm package



Note: Dimensions shown are in millimeters (mm).

Figure 32. Reel schematic

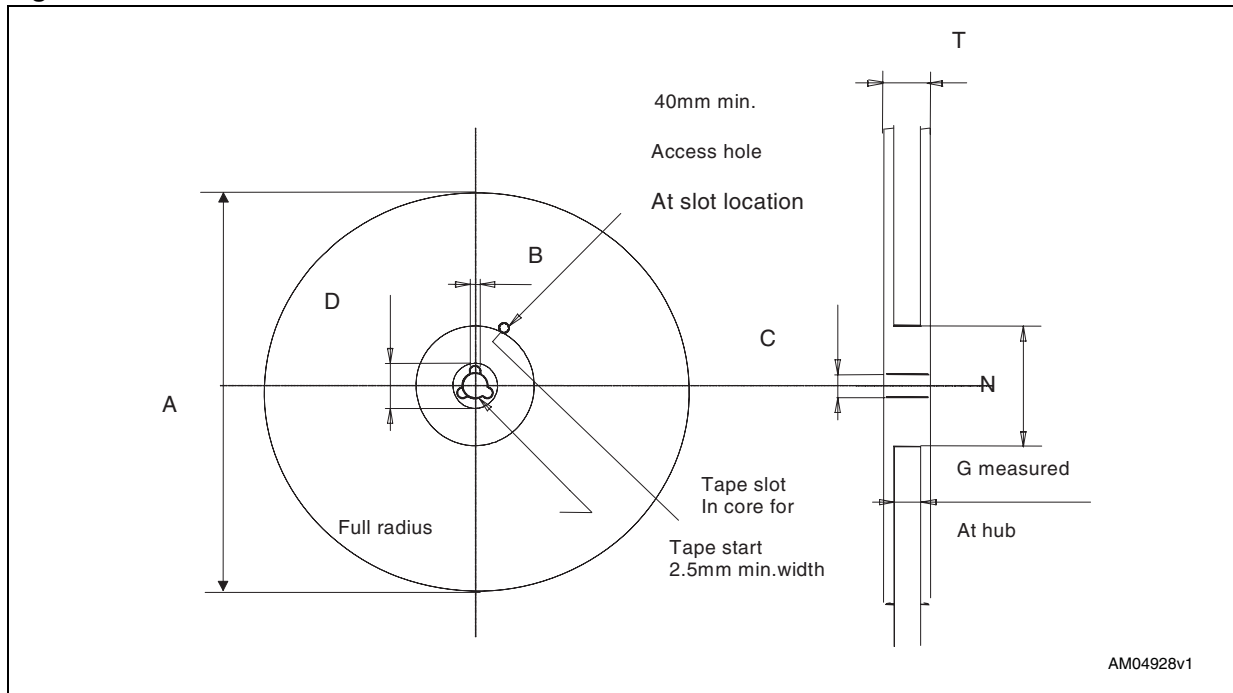

Table 21. Reel dimensions for 12 mm carrier tape - QFN16 and LCC8 packages

A (max)	B (min)	C	D (min)	N (min)	G	T (max)
330 mm (13-inch)	1.5 mm	13 mm ± 0.2 mm	20.2 mm	60 mm	12.4 mm + 2/-0 mm	18.4 mm

Note: The dimensions given in [Table 21](#) incorporate tolerances that cover all variations on critical parameters.

7 Part numbering

Table 22. Ordering information scheme

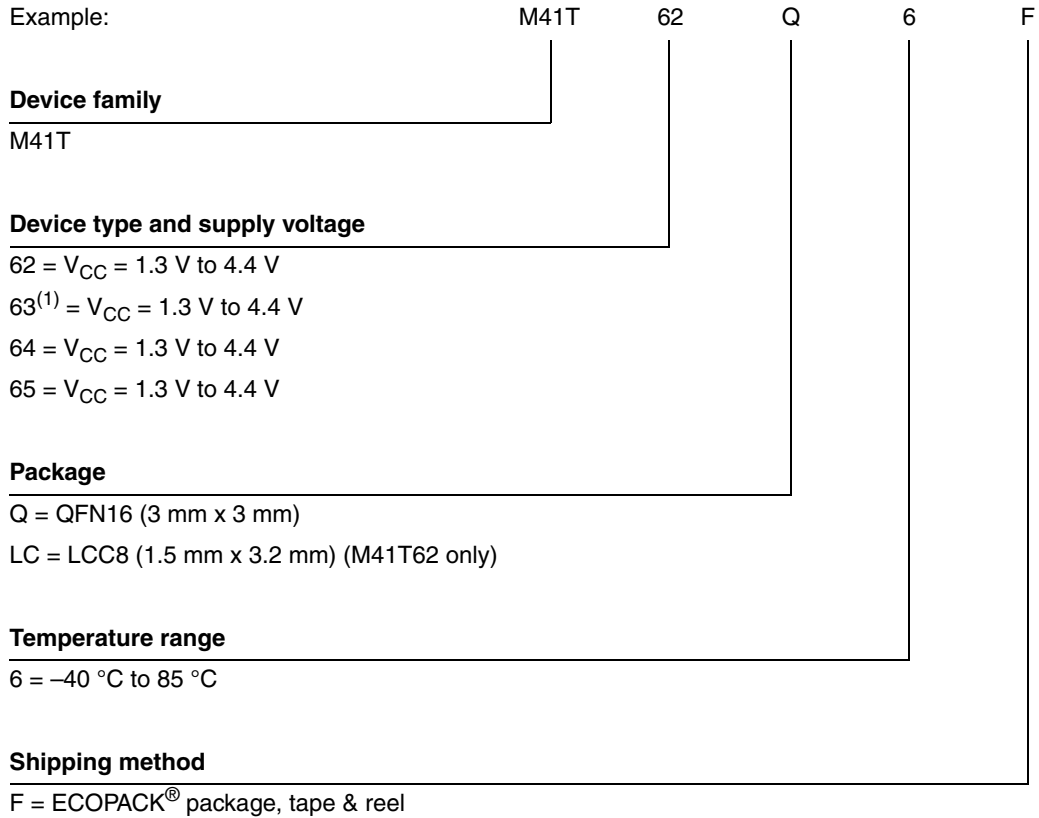

1. Contact the ST sales office for availability.

For other options, or for more information on any aspect of this device, please contact the ST sales office nearest you.

8 Revision history

Table 23. Document revision history

Date	Revision	Changes
26-Jan-2010	12	Minor textual changes; updated Section 3.2 ; footnote 3 in Table 11 ; footnote 1 in Table 15 ; text in Section 6 ; Table 16 , 18 .
07-May-2010	13	Updated title of datasheet, Features , Section 1 , Section 3.1 , 3.2 , 3.4 , 3.10 , Section 4 , Figure 23 , Table 16 ; added Figure 20 , added embedded crystal package LCC8 (updated Figure 1 , 5 , 29 , Table 22).
25-May-2010	14	Removed LCC8 package option throughout document; removed footnote from Table 14 .
24-Mar-2011	15	Updated Table 1 , 17 , 22 ; added LCC8 package option throughout datasheet; added tape and reel specifications for packages (Figure 30 , 31 , 32 , Table 20 , 21).
22-Jun-2011	16	Updated Features ; updated LCC8 package height in Figure 29 .

Please Read Carefully:

Information in this document is provided solely in connection with ST products. STMicroelectronics NV and its subsidiaries ("ST") reserve the right to make changes, corrections, modifications or improvements, to this document, and the products and services described herein at any time, without notice.

All ST products are sold pursuant to ST's terms and conditions of sale.

Purchasers are solely responsible for the choice, selection and use of the ST products and services described herein, and ST assumes no liability whatsoever relating to the choice, selection or use of the ST products and services described herein.

No license, express or implied, by estoppel or otherwise, to any intellectual property rights is granted under this document. If any part of this document refers to any third party products or services it shall not be deemed a license grant by ST for the use of such third party products or services, or any intellectual property contained therein or considered as a warranty covering the use in any manner whatsoever of such third party products or services or any intellectual property contained therein.

UNLESS OTHERWISE SET FORTH IN ST'S TERMS AND CONDITIONS OF SALE ST DISCLAIMS ANY EXPRESS OR IMPLIED WARRANTY WITH RESPECT TO THE USE AND/OR SALE OF ST PRODUCTS INCLUDING WITHOUT LIMITATION IMPLIED WARRANTIES OF MERCHANTABILITY, FITNESS FOR A PARTICULAR PURPOSE (AND THEIR EQUIVALENTS UNDER THE LAWS OF ANY JURISDICTION), OR INFRINGEMENT OF ANY PATENT, COPYRIGHT OR OTHER INTELLECTUAL PROPERTY RIGHT.

UNLESS EXPRESSLY APPROVED IN WRITING BY AN AUTHORIZED ST REPRESENTATIVE, ST PRODUCTS ARE NOT RECOMMENDED, AUTHORIZED OR WARRANTED FOR USE IN MILITARY, AIR CRAFT, SPACE, LIFE SAVING, OR LIFE SUSTAINING APPLICATIONS, NOR IN PRODUCTS OR SYSTEMS WHERE FAILURE OR MALFUNCTION MAY RESULT IN PERSONAL INJURY, DEATH, OR SEVERE PROPERTY OR ENVIRONMENTAL DAMAGE. ST PRODUCTS WHICH ARE NOT SPECIFIED AS "AUTOMOTIVE GRADE" MAY ONLY BE USED IN AUTOMOTIVE APPLICATIONS AT USER'S OWN RISK.

Resale of ST products with provisions different from the statements and/or technical features set forth in this document shall immediately void any warranty granted by ST for the ST product or service described herein and shall not create or extend in any manner whatsoever, any liability of ST.

ST and the ST logo are trademarks or registered trademarks of ST in various countries.

Information in this document supersedes and replaces all information previously supplied.

The ST logo is a registered trademark of STMicroelectronics. All other names are the property of their respective owners.

© 2011 STMicroelectronics - All rights reserved

STMicroelectronics group of companies

Australia - Belgium - Brazil - Canada - China - Czech Republic - Finland - France - Germany - Hong Kong - India - Israel - Italy - Japan - Malaysia - Malta - Morocco - Philippines - Singapore - Spain - Sweden - Switzerland - United Kingdom - United States of America

www.st.com

